

Manual

# Funktionsdecoder

## FD-R Basic.3

Item numbers 42-01180 | 42-01181

Front



Back



DCC

MM



tams elektronik



## Contents

1. Getting started.....	4
2. Safety instructions.....	6
3. Safe and correct soldering.....	9
4. Operation overview.....	10
4.1. Digital operation.....	10
4.2. Analogue mode.....	10
4.3. Function outputs.....	11
4.4. Triggering the actions.....	14
4.5. Feedback with RailCom <sup>®</sup> .....	14
5. Technical specifications.....	16
6. Connections.....	17
6.1. Connector pin assignment FD-R Basic.3.....	18
6.2. Connecting accessories to the outputs.....	19
6.3. Connecting LEDs to the function outputs.....	20
6.4. Connecting inductive loads.....	22
6.5. Connecting the switching input.....	23
6.6. Connecting a buffer capacitor/buffer circuit.....	25
6.7. Fixing the decoder.....	26
7. Programming.....	27
8. Configuration variables and registers.....	29
8.1. Basic settings.....	30
8.2. Function mapping.....	31
8.3. Effects of the outputs.....	38
8.4. Settings for the switching input.....	41
8.5. RailCom settings.....	42

8.6. Settings for driving operation.....	43
8.7. Settings for analogue mode.....	45
8.8. Setting the address.....	46
8.9. Auxiliary functions.....	47
8.10. Information.....	48
9. Check list for troubleshooting.....	49
10. Guarantee bond.....	52
11. EU Declaration of Conformity.....	53
12. Declarations concerning the WEEE directive.....	53
13. The asterisks **.....	54

## **Version 1.0 | 06/2021 | © Tams Elektronik GmbH**

All rights reserved, in particular the right of reproduction, distribution and translation. Copies, reproductions and alterations in any form require the written permission of Tams Elektronik GmbH. We reserve the right to make technical changes.

### **Printing the manual**

The formatting is optimised for double-sided printing. The standard page size is DIN A6. If you prefer a larger display, printing on DIN A5 is recommended.

## 1. Getting started

### How to use this manual

This manual will help you step by step to mount and commission the decoder safely and correctly. Before you connect the decoder and put it into operation, please read this manual completely, particularly the chapter on safety instructions and the checklist for trouble shooting. You will then know where to take care and how to prevent mistakes which take a lot of effort to correct.

Keep this manual safely so that you can solve problems in the future. If you pass the decoder on to another person, please pass on the manual with it.

### Intended use

The function decoder FD-R Basic.3 is designed to be operated according to the instructions in this manual in model building, especially in digital model railroad layouts. Any other use is inappropriate and invalidates any guarantees.

The function decoder should not be mounted by children under the age of 14.

Reading, understanding and following the instructions in this manual are mandatory for the user.

### Available versions

Connecting wires	FD-R Basic.3 (item number)
without wires	42-01180
with wires (cable length: 100 mm)	42-01181

## Checking the package contents

Please make sure that your package contains:  
one or five function decoders, depending on the version with or without soldered connecting wires.

### For mounting and connecting the decoder you need:

- a soldering iron with temperature control and a thin tip and a deposit stand or a controlled soldering station
- a scraper, rag or sponge
- a heat-resistant pad
- a small pair of side cutters and wire strippers
- tweezers and flat-nose pliers if necessary
- electronic solder (preferably 0.5 to 0.8 mm diameter)

In order to connect a decoder without soldered connecting wires you will also need wire. Recommended cross sections:

- $\geq 0,04 \text{ mm}^2$  for the connections to the function outputs,
- $\geq 0,05 \text{ mm}^2$  for the connections to the current collectors or slider

### To bridge short current interruptions you need:

- an electrolytic capacitor with a capacity of 100 to 470  $\mu\text{F}$  and a proof voltage of minimum 25 V or
- a buffer circuit, e.g.
  - USV-mini 0.47 (capacity 0.47 F, item no. 70-02215 or 70-02216)
  - USV mini 1.0 (capacity 1.0 F, item no. 70-02225 or 70-02226)
  - USV mini 1.5 (capacity 1.5 F, item no. 70-02235 or 70-02236).

### To trigger switching operations automatically, you need:

- a reed contact 1 x closing contact (e.g. item-no. 84-53110) or
- a Hall-sensor (e.g. item-no. 84-53210)
- permanent magnets (e.g. neodymium magnets  $\varnothing$  3mm, thickness = 2 mm, item-no. 84-53990)

## 2. Safety instructions



### **Caution:**

Integrated circuits (ICs) are inserted on the decoder. They are sensitive to static electricity. Do not touch components without first discharging yourself. Touching a radiator or other grounded metal part will discharge you.

### **Mechanical hazards**

Cut wires can have sharp ends and can cause serious injuries. Watch out for sharp edges when you pick up the PCB.

Visibly damaged parts can cause unpredictable danger. Do not use damaged parts: recycle and replace them with new ones.

### **Electrical hazards**

- Touching powered, live components,
  - touching conducting components which are live due to malfunction,
  - short circuits and connecting the circuit to another voltage than specified,
  - impermissibly high humidity and condensation build up
- can cause serious injury due to electrical shock. Take the following precautions to prevent this danger:
- Never perform wiring on a powered module.
  - Assembling and mounting the kit should only be done in closed, clean, dry rooms. Beware of humidity.
  - Only use low power for this module as described in this manual and only use certified transformers.
  - Connect transformers and soldering irons only in approved mains sockets installed by an authorised electrician.
  - Observe cable diameter requirements.
  - After condensation build up, allow a minimum of 2 hours for dispersion.

- Use only original spare parts if you have to repair the kit or the ready-built module.

### **Fire risk**

Touching flammable material with a hot soldering iron can cause fire, which can result in injury or death through burns or suffocation. Connect your soldering iron or soldering station only when actually needed. Always keep the soldering iron away from inflammable materials. Use a suitable soldering iron stand. Never leave a hot soldering iron or station unattended.

### **Thermal danger**

A hot soldering iron or liquid solder accidentally touching your skin can cause skin burns. As a precaution:

- use a heat-resistant mat during soldering,
- always put the hot soldering iron in the soldering iron stand,
- point the soldering iron tip carefully when soldering, and
- remove liquid solder with a thick wet rag or wet sponge from the soldering tip.

### **Dangerous environments**

A working area that is too small or cramped is unsuitable and can cause accidents, fires and injury. Prevent this by working in a clean, dry room with enough freedom of movement.

## Other dangers

Children can cause any of the accidents mentioned above because they are inattentive and not responsible enough. Children under the age of 14 should not be allowed to mount vehicle decoders.

**Caution:**

Little children can swallow small components with sharp edges, with fatal results! Do not allow components to reach small children.

In schools, training facilities, hobby and self-help workshops, the assembly, installation and operation of electronic modules must be supervised by trained personnel.

In commercial facilities, the relevant accident prevention regulations must be observed.



### 3. Safe and correct soldering

**Caution:**

Incorrect soldering can cause dangers through fires and heat. Avoid these dangers by reading and following the directions given in the chapter **Safety instructions**.

- Use a soldering iron with temperature control, which you set to approx. 300 °C.
- Only use electronic solder with a flux.
- Never use soldering fluid or soldering grease when soldering electronic circuits. These contain an acid that destroys components and conductor paths.
- Solder quickly: Soldering for too long can detach solder pads or tracks or even destroy components.
- Hold the soldering tip on the soldering point so that it touches the wire and the pad at the same time. Add (not too much) solder simultaneously. As soon as the solder begins to flow, remove it from the soldering point. Then wait a moment for the solder to flow well before removing the soldering iron from the soldering joint.
- Do not move the created solder joint for about 5 seconds.
- A clean, non-oxidized soldering tip is essential for a perfect soldering joint and good soldering. Therefore, before each soldering, wipe off excess solder and dirt with a damp sponge, a thick damp cloth or a silicone wiper.
- After soldering, check (preferably with a magnifying glass) whether connections or tracks have been bridged with solder by mistake. This can lead to malfunction or destruction of components or, in the worst case, the complete circuit. You can re-liquefy excess solder with the clean hot soldering tip. The solder then flows from the board onto the soldering tip.

## 4. Operation overview

### 4.1. Digital operation

The function decoder is a multiple protocol decoder, that can operate with and automatically recognise both DCC or Motorola formats.

	DCC	Motorola (MM)
Number of addresses	127 basic addresses or 10.239 extended addresses	255
Speed level modes	14, 28 or 128	14
Programming	configuration variables (direct programming, DCC conform) or POM (programming on main = main track programming)	registers

### 4.2. Analogue mode

The function decoder can also be used in analogue model railway layouts run with an D.C. speed control, but **not** with an A.C. speed control.

#### **Automatic analogue recognition**

When putting the vehicle on the rails the decoder recognizes automatically if it is run in analogue or digital mode and sets the corresponding operation mode. The automatic analogue recognition can be switched off, e.g.

- if the decoder suddenly switches to analogue mode in digital operation (e.g. as a result of interference voltages whose cause is difficult to localise);
- if a value for the Packet Time Out is programmed to perform a forced stop in case of track voltage failure or shutdown.

### **Switching the function outputs**

Switching the function outputs on or off is not possible in analogue mode. The outputs can be programmed with the digital central unit so that they are either switched on or off in analogue mode. The effects set for the outputs are active in analogue mode as well.

Outputs that are switched depending on the direction are switched on or off in analogue mode according to the direction of travel. When operated in analogue d.c. layouts this applies only to lamps or accessories where the return conductor is connected to the decoder's common return conductor for all function outputs.

## **4.3. Function outputs**

The decoder has four function outputs with a maximum current of 300 mA each (F0f, F0r) or 100 mA each (AUX1, AUX2) for the connection of additional accessories (e.g. lighting, smoke generator, electrical coupling). Note: The maximum total current of the decoder is 700 mA.

### **Function mapping according to RCN-227**

Assigning the functions to the outputs follows RailCommunity standard RCN-227. It is possible to assign one or several outputs to each function (F0 to F28, separately for forward and backward motion for each function). In addition, it is possible to assign another function as an "OFF"-switch to the functions.

This mode of function mapping allows to implement special features, e.g.:

- Switching on and off depending on the direction of travel.
- Shunting light: When switching to shunting mode the signals for shunting locomotive are switched on and those for standard operation switched off.
- Switching off the locomotive 's taillights when connecting wagons.

<b>Effects of the outputs</b>	adjustable for outputs			
Switching on and off depending on the direction of travel	F0f	F0r	AUX1	AUX2
Shunting light	F0f	F0r	AUX1	AUX2
Inverted switching	F0f	F0r	AUX1	AUX2
Flashing	F0f	F0r	AUX1	AUX2
Kick function	F0f	F0r	AUX1	AUX2
Dimming	F0f	F0r	AUX1	AUX2

<b>Programming the effects</b>	
Switching depending on the direction of travel The direction-dependent outputs are switched over either immediately when the direction is changed or only when speed level 0 is reached after a change of direction.	Function Mapping CV programming (CV 63)
Shunting light	Function Mapping
Inverted switching When set to position "on" the assigned function output will be switched off, when set to position "off" switched on.	CV programming (CV 58-60)

<b>Programming the effects</b>	
<p><b>Flashing</b></p> <p>By assigning the flashing function to 2 outputs and the "inverted switching" function to one of the two outputs, an alternating flashing is generated.</p> <p>The flashing frequency is set separately for each output.</p>	<p>CV programming (CV 58-60, CV 101-104)</p>
<p><b>Kick function</b></p> <p>The outputs first receive full voltage for a maximum of approx. 25.5 seconds and are then switched off. The kick time is set separately for all outputs.</p> <p>Example of use: Some types of electrical couplings require full voltage to decouple. However, the voltage should be switched off after uncoupling in order to protect the couplings.</p>	<p>CV programming (CV 58-60, CV 99)</p>
<p><b>Dimming</b></p> <p>To reduce the voltage at the output.</p> <p>Example of use: The lights of older vehicles intended for analogue operation can be dimmed and then do not need to be replaced after the decoder has been installed.</p>	<p>CV programming (CV 47-50)</p>

## 4.4. Triggering the actions

The function outputs are switched on and off and the shunting mode is (de)activated:

- through the assigned function(s) and / or
- automatically via the switching input. The switching input is triggered via external contacts, e.g. via reed contact or Hall sensors in combination with permanent magnets in the track.

### **Assignment of the actions to the functions (Function Mapping)**

The assignment of the actions controlled by the decoder to the functions is freely selectable, each separately for forward and reverse travel.

Actions	DCC format	MM format
Outputs F0f, F0r, AUX1 and AUX2	F0 to F28	F0 to F4
Shunting mode (shunting light)		

## 4.5. Feedback with RailCom®

The function decoder FD-R Basic.3 is a RailCom transmitter and meets the requirements of the RailCommunity standard RCN-217 "RailCom DCC feedback protocol" (status 01.12.2019) for mobile decoders (vehicle decoders). RCN-217 has been published on:

[www.railcommunity.org](http://www.railcommunity.org)

Sending RailCom messages is possible in layouts with a DCC signal on the rails only. It is not possible to use the RailCom-function in a pure Motorola environment.

### **Background information: RailCom-messages of vehicle decoders**

In channel 1, the vehicle decoders transmit their DCC address after

each DCC command directed to any vehicle decoder. Channel 1 can be set "dynamically", i.e. the decoder will only transmit its address in channel 1 until a DCC command is directed to it. This frees the channel for the messages of other decoders to which no command has yet been sent or which are not yet known to the system.

In channel 2, vehicle decoders send their feedback as soon as a DCC command is sent to their address.

### **Background information: Dynamic RailCom information**

"Dynamic information" mean contents of CVs (RailComCVs 64-127) which change during operation (e.g. real speed, reception statistics, tank content). If needed, they are sent by the decoder spontaneously.

The reception statistics are kept by the vehicle decoder, and reported as number of faulty data packages in relation to the total number of data packages. These statistics allow conclusions on the transmission quality between vehicle and rails.

The function decoder FD-R Basic.3 can send the following dynamic RailCom information:

- reception statistics

RailCom® is a registered trademark of Lenz Elektronik GmbH. In order to increase the readability of this text, we do without referring to this with every use of the term RailCom.

## 5. Technical specifications

Data format	DCC and MM
Feedback log	RailCom
Supply voltage	12-24 Volt digital voltage or analogue driving transformer (max. 18 V <b>direct</b> voltage)
Current consumption (without connected loads) max.	max. 20 mA
Max. total current	700 mA
Number of outputs	4
Max. current / output	F0f and F0r: 300 mA AUX1 and AUX2: 100 mA
Number of inputs	1
Connection for buffer capacitor or buffer circuit	1
Buffer capacitor	Capacity: 100 to 470 $\mu$ F Proof voltage: $\geq$ 15 V
Protected to	IP 00
Ambient temperature in use	0 ... +60 °C
Ambient temperature in storage	-10 ... +80 °C
Comparative humidity allowed	max. 85 %
Dimensions PCB	approx. 13 x 9,5 x 3,5 mm
Weight	without wires: approx. 0,8 g with wires: approx. 1,3 g



## 6. Connections

### **Avoid irreparable damage!**

Observe the following instructions to avoid damage to the decoder:

#### **1. No conductive connections to metal parts or rails!**

Avoid all conductive connections between the decoder or consumers connected to the return conductor for all functions on the one hand, and metal parts of the vehicle or the rails on the other hand. Connections are caused e.g. by insufficiently insulated connecting cables (even at the stripped ends of unused connecting cables!) or insufficient fastening and insulation of the decoder or consumers. Danger of short circuit!

#### **2. Do not connect the return conductor to vehicle ground!**

You should under no circumstances connect the decoder's common return conductor for all function outputs to vehicle ground. Risk of short circuit!

#### **3. Exclude overload!**

Before connecting lights and additional accessories, check that the current is below the maximum permissible values and that the total current is not exceeded. If the permissible current is exceeded, the decoder may be damaged during commissioning.

#### **4. Not for use in analogue AC systems!**

The FD-R Basic.3 is only approved for analogue operation with DC driving transformers. If it is used in analogue AC systems, irreparable damage to the components of the decoder may occur.

## 6.1. Connector pin assignment FD-R Basic.3

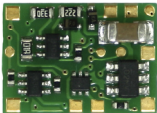
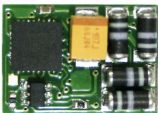
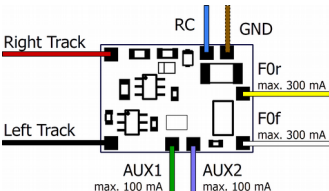
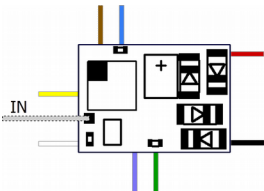
Front	Back
	
	

	Colour of wire	Connection (for use of settings in state of delivery)
Right track	red	Right current collector (or vehicle ground)
Left track	black	Left current collector (or slider)
AUX1	green	AUX1 (function key F1)
AUX2	violet	AUX2 (function key F2)
F0f	white	Lighting forward motion (function key F0)
F0r	yellow	Lighting backward motion (function key F0)
GND		Negative pole (-) of buffer capacitor / Earth connection IN
RC	blue	Common return conductor for all function outputs (+) Positive pole (+) of buffer capacitor
IN		Switching input (back side)

## 6.2. Connecting accessories to the outputs

### **Caution:**

The maximum current of the accessory must not exceed the maximum current of the output to which you connect it. The output may otherwise be irreparably damaged!

Disconnect any existing diodes in the leads to the lamps, otherwise the lamps might not light. Connect the lamps and the accessories to the function outputs of the decoder. If the lamp or the accessory is already connected with one side to vehicle ground, the connection is complete. If not, connect the second side of the lamp or the accessory to the decoder's common return conductor for all function outputs.

You find the factory (default) settings in the lists with the connector pin assignments (page 18). You can assign the outputs to the function keys voluntarily by setting the configuration variables.

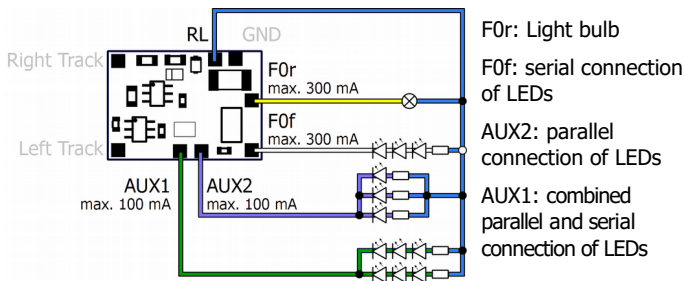

Fig. 1: Examples for the connection of accessories and LEDs to the function outputs

### 6.3. Connecting LEDs to the function outputs

The decoder's function outputs switch respective to the decoder ground. For that reason you must connect the cathodes (-) of the LEDs to the function outputs and the anodes (+) to the decoder's common return conductor for all function outputs (RC).



#### **Caution:**

You must always operate LEDs via a series resistor! Otherwise LEDs will be destroyed when put into operation or have a significantly reduced duration of life. If you do without a series resistor, other components take over their function (e.g. rails, wheels, current collectors). This can lead to a change in the digital signal and thus to interference in digital operation.

Determine the required resistance value for the peak value of the working voltage available at the return conductor (RC).

#### **Determining the peak value of the working voltage**

- with regulated boosters:  
output (= track) voltage of the booster - 1 V\*
  - with not regulated boosters or analogue driving transformers:  
(1,4 x the nominal voltage specified on the transformer) - 1 V\*
- \* 1 V gets "stuck" in the rectifier of the decoder.

#### **Serial connection of LEDs**

When you want to connect several LEDs to one output you can switch them in series via a common series resistor. The current consumption is max. 20 mA for all LEDs, depending on the series resistor's value. The maximum number of LEDs to be connected in series results from

$$\frac{\text{Peak value of the operating voltage}}{\text{- sum of the forward voltages of all LEDs}} > 0$$

The advantage of this solution is the low current consumption.

In order to determine the necessary series resistor for a serial LED's connection first add the forward voltages of all LEDs. The forward voltages depend on the lighting colour and should be given in the technical specifications. In case there is no manufacturer information available, you can take as a basis 4 V for white and blue LEDs and 2 V for yellow, orange, red and green LEDs.

The remaining voltage has to be "eliminated" by a resistor. The formula for the calculation of the resistor is:

$$\text{required } R_V [\text{Ohm}] = ( U_B [\text{V}] - \sum U_F [\text{V}] ) / ( I_F [\text{mA}] \times 0.001 )$$

$U_B$  = operating voltage (peak value) |  $\sum U_F$  = sum of the forward voltages of all LEDs

$I_F$  = current with max. luminosity

### Parallel connection of LEDs

Alternatively, you can connect several LEDs in parallel, each via a series resistor of its own. The current consumption is max. 20 mA for all LEDs, depending on the series resistor's value. The maximum number of LEDs to be connected in parallel results from

maximum current at the output

- sum of the current consumption of all LEDs

> 0

Advantageous with this solution is that the LEDs already lighten when their forward voltage has been reached (2 to 4 V, depending on the fluorescent colour), which makes this solution suitable for analogue mode. Disadvantageous is the high current consumption.

The formula for the calculation of the resistor is:

$$\text{required } R_V [\text{Ohm}] = ( U_B [\text{V}] - U_F [\text{V}] ) / ( I_F [\text{mA}] \times 0.001 )$$

$U_B$  = operating voltage (peak value) |  $U_F$  = forward voltage of the LED

$I_F$  = current with max. luminosity

In order to save current, you can limit the LEDs' current consumption to 10 mA, which normally does not cause a visible loss of luminance.

## 6.4. Connecting inductive loads

When connecting inductive loads (e.g. TELEX couplings, relays or other accessories with coils), you should switch a free-wheeling diode (e.g. 1N400x) in parallel, in order to avoid damage at the output. Check to connect the anode of the diode to the function output.

### Connecting accessories via a relay

When you want to switch an accessory / accessories via the decoder, which connection would lead to exceeding the maximum current at the output or of the decoder, you can switch the accessories via a relay (e.g. 1xUm 1A 12V, item-number84-61010) and connect them directly to the vehicle's current collector.

The current consumed by the relay depends on its type. The relay named in the example needs approx. 100 mA.

As described in the section "Connecting inductive loads" you should switch a free-wheeling diode (e.g. 1N400x) in parallel to the relay.

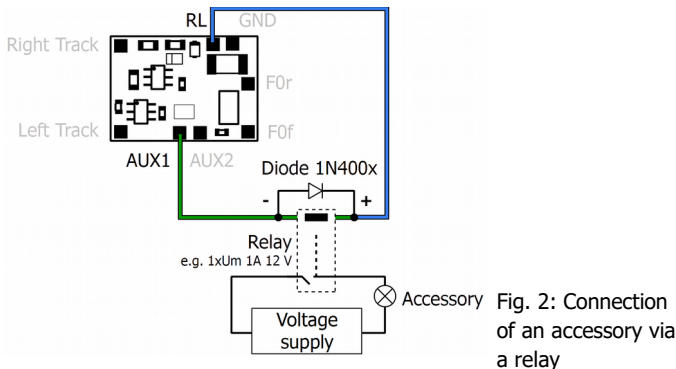

Fig. 2: Connection of an accessory via a relay

## 6.5. Connecting the switching input

The switching input switches against decoder ground and can therefore be connected to all (external) circuits that can be used to establish a ground connection. It is possible, for example, to connect reed contacts or Hall sensors which establish the ground connection as soon as they enter the magnetic field of a permanent magnet.

### Connection of a reed contact

You can use both normally open contacts and changeover switches (changeover contacts).

**⚠ Note:** The glass bulbs of reed contacts are sensitive to mechanical damage!

Connect reed contacts to the switching input and the ground connection of the decoder (GND). Reed contacts are not polarized, so you can assign the two connections as you wish.

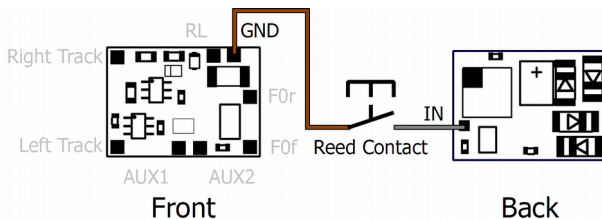



Fig. 3: Connection of a reed contact to the switching input

## Connection of a Hall sensor

Pay attention to the correct polarity when connecting Hall sensors.

Assignment of the connections:

Hall sensor	Decoder	 Mixing up the connections "ground terminal" and "supply voltage terminal" may damage the Hall sensor.
Ground terminal (L)	Ground terminal (GND)	
Supply voltage terminal (+)	Voltage output (RC)	
Output	Switching input (IN)	

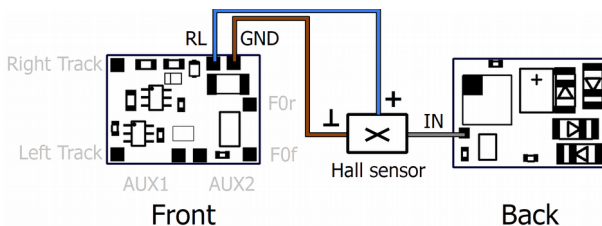

Fig. 4: Connection of a Hall sensor to the switching input



## 6.6. Connecting a buffer capacitor/buffer circuit

In sections with bad contact to the rails (e.g. when running over turnouts) or with a (e.g. construction-related) bad current consumption of the vehicle, the power supply of the decoder can be interrupted briefly. In analogue mode the effects are usually small, but in digital mode massive disturbances can be the result: e.g. flickering of the lights up to automatic switching to analogue mode. This can be remedied by connecting a backup capacitor or a special buffer circuit.

### Connection of a backup capacitor

The capacitor must have a capacity of at least 100  $\mu\text{F}$  and a maximum of 470 F and a proof voltage of at least 25 V. Pay attention to the correct polarity when connecting!

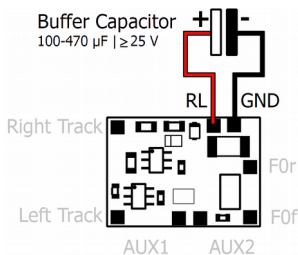

Fig. 5: Connection of a backup capacitor ("buffer electrolytic capacitor")

### Connection of a buffer circuit

The capacity of buffer circuits is considerably larger than that of buffer capacitors (e.g. UPS-mini with 0.47 F, 1.0 F or 1.5 F). Use a buffer circuit according to RCN 530 that can be connected without a control line, e.g. UPS-mini, part no. 70-0221x, 70-0222x, 70-0223x.

When connecting, follow the instructions for the buffer circuit.

## 6.7. Fixing the decoder

After having finished all connections you should fix the decoder, to avoid short circuits by contact to metal parts of the vehicle, for example. You can use double sided adhesive tape for it or a decoder holder (item number 70-01810 or 70-01820), for example.

## 7. Programming

### Programming with DCC central units

You can program the configuration variables (CV) of the decoder from the digital central unit, you can use main track programming as well. See the chapter in the manual of your central unit where the byte wise programming of configuration variables (CVs) (Direct programming) and main track programming (POM) are explained.

Register programming is not supported by the decoder. With DCC central units that allow only register-programming it is **not** possible to program the FD-R Basic.3.

### Programming with Motorola central units

In Motorola format the settings are saved in registers. The registers have the same numbers as the configuration variables (CVs) for the DCC format.

Please note: If you use a central unit for both DCC and Motorola format it is recommended to program the decoder in the DCC format. After having finished programming the decoder it is possible to control it in Motorola format as well.

Please note: You should connect a lamp or a LED to at least F0f or F0r before starting to program the decoder with a Motorola central unit, as the decoder shows the status of the programming by flashing the lighting connected to these outputs. The flashing frequency shows, which input the decoder expects:

Slow flashing	Fast flashing
<b>Number</b> of the register to be programmed	<b>Value</b> of the register to be programmed

Put the vehicle on a track oval or a track section connected to the central unit's track output (not to the connection for the programming track). Make sure no other vehicle than the one you intend to program is set on the track as the decoder inside this vehicle might be programmed as well.

Starting the programming mode	Programming the decoder
<ol style="list-style-type: none"> <li>1. Switch on the central unit or perform a reset at the central unit (pushing "stop" and "go") simultaneously.</li> <li>2. Set the current decoder address (default value: 3) or the address "80".</li> <li>3. Set all functions to "off".</li> <li>4. Push button "stop" → switch off the track voltage.</li> <li>5. Operate the direction switch and hold it in that position. Push the button "go" at once.</li> <li>6. As soon as the lighting flashes, release the direction switch.</li> </ol>	<ol style="list-style-type: none"> <li>1. Enter the number of the register as a Motorola-address. If necessary: with a leading "0".</li> <li>2. Operate the direction switch. → Lighting flashes faster.</li> <li>3. Enter the value you want to set into the register (as Motorola-address).</li> <li>4. Operate the direction switch. → Lighting flashes more slowly.</li> </ol> <p>If necessary: repeat steps 1 to 4 for all registers to be programmed.</p> <p style="text-align: center;">Push button "stop".</p>
→ Programming mode	→ End of programming mode

### Programming with the Central Station I and the Mobile Station

With the Central Station I or the Mobile Station of Märklin\*\* you can program the registers. Select the article number 29750 from the locomotive database and program the decoder as described for this article in the Central Station's or Mobile Station's manual.

## 8. Configuration variables and registers

The following lists shows all configuration variables (for the DCC format) and registers (for the Motorola format), that can be set for the function decoder.

Registers and configuration variables (CVs) have identical numbers, they are shown in the tables in the column "No.". The defaults are those values set in the state of delivery and after a reset.

Please note: With variables destined to set several parameters, the input value has to be calculated by adding the numerical values assigned to the desired parameters.

## 8.1. Basic settings

Name	No.	Input values (Default)	Remarks and tips
Configuration data 1	29	0 ... 255 (14)	Direction "Standard" 0
			Reverse direction 1
			14 speed levels 0
			28 or 128 speed levels 2
			Analogue recognition off 0
			Analogue recognition on 4
			RailCom off 0
			RailCom on 8
			Basic addresses 0
For DCC format only:			Extended addresses 32
Tip: If the use of extended addresses is activated in CV 29, the decoder does not react to signals in Motorola format!			

Example: CV 29 = 0 → Direction = "Standard". 14 speed levels . Automatic analogue recognition = "off". RailCom = "off". Basic addresses.

Example: CV 29 = 46 → Direction = "Standard". 28 or 128 speed levels in DCC mode. Automatische Analogerkennung = "on". RailCom = "on". Extended addresses.

## 8.2. Function mapping

The assignment of the actions controlled by the decoder

- switching the function outputs on and off
- (de)activation of the special function "Shunting mode / Shunting light" (SM)

to the functions is carried out according to RailCommunity standard RCN-227. Note: Function mapping is not possible with pure Motorola central units.

To get access to the corresponding memory area (the so-called "page"), the values for "Function mapping" must be set in CV 31 and 32 (= default values).

Name	No.	Input values (Default)	Remarks and tips
Index for higher pages	31	0 ... 255 (0)	Function mapping 0
	32	0 ... 255 (42)	Function mapping 42

According to RCN-227, eight configuration variables (CVs) are assigned to each function (F0 to F28) (four each for forward ("f") and reverse ("r")). Six of them are used for the function decoder FD-R Basic.3 (3 for forward and 3 for reverse):

- 2 CVs for the outputs (F0f, F0r, AUX1 and AUX2): Here you set which outputs are switched with the function.
- 1 CV for the special function "Shunting mode / Shunting light" (SM): Here you set which function is used to activate the shunting mode.
- Switch-off function: Here you can define a function with which you can switch **off** the actions assigned to the function when switching **on**. The value "255" determines that the actions are switched off with **no** function.

	Outputs				not in use	Special functions	off/on with function
	F0f	F0r	AUX1	AUX2			
Values	1	2	4	8	0	4 (on)	F0, F1, F2, ..., F28
Input values	0, 1, 2, 3, 4,..., 31				0	0, 4	0, 1, 2,... 28, 255

CV name	Outputs		CV- No.	Def. value	CV- Nr.	Def.- wert	CV- No.	Default value
	CV- No.	Default value						
F0 f	257	(1) F0f on during forward travel	258	(0)	259	(0)	260	(255)
F0 r	261	(2) F0r on during backward travel	262	(0)	263	(0)	264	(255)
F1 f	265	(4) AUX1 on during forward travel	266	(0)	267	(0)	268	(255)
F1 r	269	(4) AUX1 on during backward travel	270	(0)	271	(0)	272	(255)
F2 f	273	(8) AUX2 on during forward travel	274	(0)	275	(0)	276	(255)
F2 r	277	(8) AUX2 on during backward travel	278	(0)	279	(0)	280	(255)
F3 f	281	(0)	282	(0)	283	(4)	284	(255)
F3 r	285	(0)	286	(0)	287	(4)	288	(255)
F4 f	289	(0)	290	(0)	291	(0)	292	(255)
F4 r	293	(0)	294	(0)	295	(0)	296	(255)
F5 f	297	(0)	298	(0)	299	(0)	300	(255)
F5 r	301	(0)	302	(0)	303	(0)	304	(255)



	Outputs				not in use	Special functions	off/on with function
	F0f	F0r	AUX1	AUX2		SM	
Values	1	2	4	8	0	4 (on)	F0, F1, F2, ..., F28
Input values	0, 1, 2, 3, 4,..., 31				0	0, 4	0, 1, 2,... 28, 255

	Outputs			not in use	Special functions	off/on with function		
CV name	CV-No.	Default value	CV-No.	Def. value	CV-Nr.	Def.-wert	CV-No.	Default value
F6 f	305	(0)	306	(0)	307	(0)	308	(255)
F6 r	309	(0)	310	(0)	311	(0)	312	(255)
F7 f	313	(0)	314	(0)	315	(0)	316	(255)
F7 r	317	(0)	318	(0)	319	(0)	320	(255)
F8 f	321	(0)	322	(0)	323	(0)	324	(255)
F8 r	325	(0)	326	(0)	327	(0)	328	(255)
F9 f	329	(0)	330	(0)	331	(0)	332	(255)
F9 r	333	(0)	334	(0)	335	(0)	336	(255)
F10 f	337	(0)	338	(0)	339	(0)	340	(255)
F10 r	341	(0)	342	(0)	343	(0)	344	(255)
F11 f	345	(0)	346	(0)	347	(0)	348	(255)
F11 r	349	(0)	350	(0)	351	(0)	352	(255)
F12f	353	(0)	354	(0)	355	(0)	356	(255)
F12 r	357	(0)	358	(0)	359	(0)	360	(255)
F13 f	361	(0)	362	(0)	363	(0)	364	(255)
F13 r	365	(0)	366	(0)	367	(0)	368	(255)

	Outputs				not in use	Special functions		off/on with function	
	F0f	F0r	AUX1	AUX2		SM			
Values	1	2	4	8	0	4 (on)	F0, F1, F2, ..., F28		
Input values	0, 1, 2, 3, 4,..., 31				0	0, 4	0, 1, 2,... 28, 255		

CV name	Outputs			not in use		Special functions		off/on with function	
	CV-No.	Default value		CV-No.	Def. value	CV-Nr.	Def.-wert	CV-No.	Default value
F14 f	369	(0)		370	(0)	371	(0)	372	(255)
F14 r	373	(0)		374	(0)	375	(0)	376	(255)
F15 f	377	(0)		378	(0)	379	(0)	380	(255)
F15 r	381	(0)		382	(0)	383	(0)	384	(255)
F16 f	385	(0)		386	(0)	387	(0)	388	(255)
F16 r	389	(0)		390	(0)	391	(0)	392	(255)
F17 f	393	(0)		394	(0)	395	(0)	396	(255)
F17 r	397	(0)		398	(0)	399	(0)	400	(255)
F18 f	401	(0)		402	(0)	403	(0)	404	(255)
F18 r	405	(0)		406	(0)	407	(0)	408	(255)
F19 f	409	(0)		410	(0)	411	(0)	412	(255)
F19 r	413	(0)		414	(0)	415	(0)	416	(255)
F20 f	417	(0)		418	(0)	419	(0)	420	(255)
F20 r	421	(0)		422	(0)	423	(0)	424	(255)
F21 f	425	(0)		426	(0)	427	(0)	428	(255)
F21 r	429	(0)		430	(0)	431	(0)	432	(255)

	Outputs				not in use	Special functions	off/on with function
	F0f	F0r	AUX1	AUX2		SM	
Values	1	2	4	8	0	4 (on)	F0, F1, F2, ..., F28
Input values	0, 1, 2, 3, 4,..., 31				0	0, 4	0, 1, 2,... 28, 255

	Outputs			not in use	Special functions	off/on with function		
CV name	CV-No.	Default value	CV-No.	Def. value	CV-Nr.	Def.-wert	CV-No.	Default value
F22f	433	(0)	434	(0)	435	(0)	436	(255)
F22 r	437	(0)	438	(0)	439	(0)	440	(255)
F23 f	441	(0)	442	(0)	443	(0)	444	(255)
F23 r	445	(0)	446	(0)	447	(0)	448	(255)
F24 f	449	(0)	450	(0)	451	(0)	452	(255)
F24 r	453	(0)	454	(0)	455	(0)	456	(255)
F25 f	457	(0)	458	(0)	459	(0)	460	(255)
F25 r	461	(0)	462	(0)	463	(0)	464	(255)
F26 f	465	(0)	466	(0)	467	(0)	468	(255)
F26 r	469	(0)	470	(0)	471	(0)	472	(255)
F27 f	473	(0)	474	(0)	475	(0)	476	(255)
F27 r	477	(0)	478	(0)	479	(0)	480	(255)
F28 f	481	(0)	482	(0)	483	(0)	484	(255)
F28 r	485	(0)	486	(0)	487	(0)	488	(255)

## Example: Programming for shunting operation

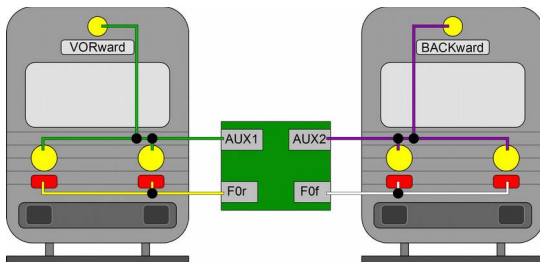

Hint: The connection of the return conductor is not shown.

	Outputs				off/on with function	
	F0f	F0r	1	2		
Values	1	2	4	8	1 ... 254	
CV name	CV-No.	Set value			CV-No.	Set value
F0 f	257	5 (outputs F0f and AUX1)			260	3 (F3=shunting operation)
F0 r	261	10 (outputs F0r and AUX2)			264	3 (F3=shunting operation)
F3 f	265	12 (outputs AUX1 and AUX2)			268	(255 = off)
F3 r	269	12 (outputs AUX1 and AUX2)			272	(255 = off)

With this programming you achieve the following effects when changing to shunting operation (here using function F3):

- the rear end signal for the active direction of motion will be switched off and
- the three-light head end signal will be switched on on both sides.

## Example: Programming for rear end signal "off" with coupled carriages

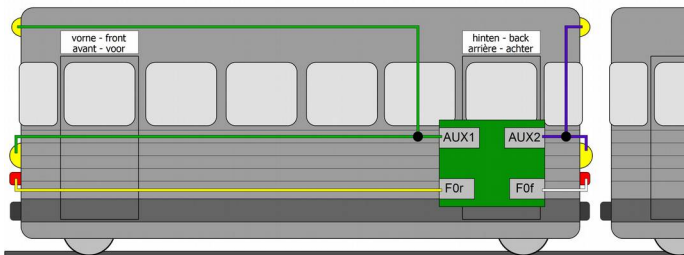

Hint: The connection of the return conductor is not shown.

	Outputs				off/on with function
	F0f	F0r	1	2	
Values	1	2	4	8	1 ... 254
CV name	CV-No.	Set value	CV-No.	Set value	
F0 f	257	5 (outputs F0f and AUX1)	260	5 (F5=coupled carriage)	
F0 r	261	10 (outputs F0r and AUX2)	264	5 (F5=coupled carriage)	
F5 f	297	4 (output AUX1)	268	(255 = off)	
F5 r	301	2 ( output F0r)	272	(255 = off)	

With this programming you achieve the following effects when changing to operation with coupled carriages (here using function F5):

- the signals appropriate for the direction of motion will be switched on and
- the signals on the side of the coupled carriages will be switched off.

## 8.3. Effects of the outputs

### Assignment of the effects to the outputs

Output	No.	Input values (Default)	Remarks and tips
F0f	57	0 ... 255 (0)	no effects 0
F0r	58	0 ... 255 (0)	Function inverted 1
AUX1	59	0 ... 255 (0)	Flashing on 2
AUX2	60	0 ... 255 (0)	Kicking on 4

Example: Alternating flashing with AUX1 and AUX2:  
 → Input value for AUX1: CV 59 = 2 | Input value for AUX2: CV 60 = 3 (1 + 2)

### Flashing frequency

Output	No.	Input values (Default)	Remarks and tips
F0f	101	1 ... 255 (20)	Setting separately for each output. 1 = highest flashing frequency 255 = lowest flashing frequency  Note: The flashing function must be switched on for the output. (CV 57 - 60)
F0r	102	1 ... 255 (20)	
AUX1	103	1 ... 255 (20)	
AUX2	104	1 ... 255 (20)	

## Kicking time

Output	No.	Input values (Default)	Remarks and tips
Kicking time ("moment-function")	99	0 ... 255 (32)	<p>Setting common for all outputs.</p> <p>0 = shortest kick time</p> <p>255 = longest kick time (= 25.5 seconds)</p> <p>Increasing the input value by "1" extends the time period by 0.1 sec.</p> <p>Note: The kick function must be switched on for the output. (CV 57 - 60)</p>

## Dimming of the outputs

Output	No.	Input values (Default)	Remarks and tips
F0f	47	1...64 (64)	<p>= Reduction of the voltage applied to the output</p> <p>1 = lowest voltage</p> <p>255 = maximum voltage</p>
F0r	48	1...64 (64)	
AUX1	49	1...64 (64)	
AUX2	50	1...64 (64)	

**Reaction to change of direction**

Output	No.	Input values (Default)	Remarks and tips
Change of direction	63	0,1 (1)	Setting common for all outputs. 0 = Direction-dependent outputs are switched immediately when the direction changes. 1 = Direction-dependent outputs are only switched over in the event of a change of direction when speed level 0 is reached.



## 8.4. Settings for the switching input

Name	No.	Input values (Default)	Remarks and tips
Assignment of the functions to the switching input	62	1 ... 255 (0)	F1 1
			F2 2
			F3 4
			F4 8
			F5 16
			F6 32
			F7 64
			F8 128
Minimum switch-on time of the switching input	97	0 ... 255 (0)	<p>= Time period for which the input remains at least on after it has been connected to ground.</p> <p>Increasing the input value by "1" extends the time period by 0.1 sec.</p> <p>0 = 0 sec. (off)</p> <p>255 = 25.5 sec.</p>
<p>Example:</p> <p>The interior lighting (here switched with F1) is to be activated automatically for the duration of the passage through a tunnel (here 10 seconds).</p> <p>CV 62 = 4 (assignment of the switching input to F3)</p> <p>CV 97 = 100 (= 10 seconds)</p>			

## 8.5. RailCom settings

Name	No.	Input values (Default)	Remarks and tips
Dynamic RailCom information	10	0,1 (1)	off 0
			Reception statistics: The decoder keeps statistics on all DCC packets and reports the number of faulty packets / total number of packets in %. 1
In order to read out RailCom information, you have to make the following additional settings: - CV 29 ("configuration data 1": RailCom on - CV 28 "RailCom channels": at least channel 2 on			
RailCom channels	28	0 ... 7 (3)	no feedback with RailCom 0
			Channel 1 on 1
			Channel 2 on 2
			Dynamic channel 1 use 4 The setting only has an effect if channel 1 is switched on.
Please note that some RailCom detectors can only receive messages on channel 1. For the decoder to send RailCom messages, RailCom must be switched on in CV 29. Further information on RailCom → Section 4.5			

## 8.6. Settings for driving operation

### Consist operation

As a standard, in multiple units (consist operation) you can only control velocity and direction. In CV 21 and 22 you can define additional functions to be switched when using the address for multiple units defined in CV 19. If the value "0" is set, the function will continue to be addressed only via the address set for the vehicle concerned in CV 1 or CV 17 and 18.

Name	No.	Input values (Default)	Remarks and tips
Functions active in consist operation (F1 to F8)	21	0 ... 255 (0)	F1 on 1
			F2 on 2
			F3 on 4
			F4 on 8
			F5 on 16
			F6 on 32
			F7 on 64
			F8 on 128
Functions active in consist operation (F0, F9 to F12)	22	0 ... 31 (0)	F0f on 1
			F0r on 2
			F9 on 4
			F10 on 8
			F11 on 16
			F12 on 32

## Setting the Packet Time Out

Name	No.	Input values (Default)	Remarks and tips
Packet Time Out	11	2 ... 255 (16)	Time period between the failure of the digital signal and the change to the alternative operation (analogue operation). Increasing the input value by "1" extends the time period by 10 ms.

Hint: If the decoder is supplied by a buffer circuit, the locomotive would continue running unplanned after an emergency stop or a signal stop caused by switching off the track voltage. To prevent this, you have to set a low value for the Packet Time Out (approx. 16) and switch off the automatic switch-over to analogue operation in CV 29.

## 8.7. Settings for analogue mode

Name	No.	Input values (Default)	Remarks and tips
Analogue mode	65	0, 1 (1)	= Procedure triggering a change of direction
			Change of polarity (d.c. layouts) 0
Functions active in analogue mode (F1 to F8)	13	0 ... 255 (0)	F1 on 1
			F2 on 2
			F3 on 4
			F4 on 8
			F5 on 16
			F6 on 32
			F7 on 64
			F8 on 128
Functions active in analogue mode (F0, F9 to F12)	14	0 ... 31 (0)	F0 on 1
			F9 on 2
			F10 on 4
			F11 on 8
			F12 on 16

## 8.8. Setting the address

Name	No.	Input values (Default)	Remarks and tips
Basic address	1	1 ... 255 (3)	Range of values: in DCC format: 1 ... 127 in MM format: 1 ... 255
<p>Tip: If a value higher than 127 is set for the basic address and the use of extended addresses in CV 29 is set to off, the decoder does not react to signals in DCC format!</p>			
Extended address	17	192 ... 255 (195)	Only for DCC format. Most central units permit entering extended addresses directly. The CVs 17, 18 and 29 are set automatically to the proper values.
	18	0 ... 255 (232)	
Consist address	19	1 ... 127 (0)	Address for consist operation (multi-traction) In DCC format only!

## 8.9. Auxiliary functions

Name	No.	Input values (Default)	Remarks and tips
Reset	8	0 ... 255	Any input value restores the settings in state of delivery.
Decoder lock	15	0 ... 255 (3)	Changing the CV values of the decoder is only possible if the values in CV 15 and 16 are identical.  By assigning specific values in CV 16 the CVs of decoders with the same address can be changed separately.
	16	0 ... 255 (3)	
Application e.g. for vehicles or train formations with several decoders with the same address (e.g. locomotive, sound, function decoders).			
Index for higher CV-Pages	31	0 (0)	Adjustable in DCC format only! Function mapping 0
	32	0 (42)	Adjustable in DCC format only! Function mapping 42
Note: If different values are entered in CV 31 and/or 32 the function mapping for the function outputs and special functions cannot be changed.			

## 8.10. Information

Name	No.	Input values (Default)	Remarks and tips
Version	7	---	Read only in DCC format!
Manufacturer	8	--- (62)	Read only in DCC format!
Permitted modes of operation	12	--- (37)	<p>Readable in DCC format only!</p> <p>Defines the permitted modes of operation for the decoder</p> <p>FD-R Basic.3:  <math>37 = 1 + 4 + 32</math>  <math>1 = DC \mid 4 = DCC \mid 32 = MM</math></p>
Method for function assignment	96	--- (2)	<p>Readable in DCC format only!</p> <p>Defines the method for assigning the functions:</p> <p>2 = Function assignment via CVs 257 to 512 in the bank selected by CV 31 = 0 and CV 32 = 42 with CVs per function according to RailCommunity standard RCN227 section 2</p>



## 9. Check list for troubleshooting

- Parts are getting very hot and/or start to smoke.



Disconnect the system from the mains immediately!

Possible cause: one or more connections are soldered incorrectly.  
→ Check the connections.

Possible cause: Short circuit between the decoder or accessories connected to the retrun conductor for all functions and metal parts of the locomotive or the rails. → Check the connections. A short circuit can result in irreparable damage.

### **Problems with switching of the functions**

- An accessory / a light does not react to switching commands.  
Possible cause: The accessory is defective or incorrectly connected.  
→ Check the accessory / the connections.

Possible cause: The output is defective (e.g. due to overload or short circuit). → Send in the decoder for check / repair (with costs).

- The lighting goes on and off when the speed levels are turned up or the lighting cannot be switched on or off.

Possible cause: The speed mode of the decoder and the digital control unit do not correspond. Example: The central is set to the mode 28 speed levels, but the decoder to the mode 14 speed levels. → Change the speed mode at the central and / or at the decoder.

### **Problems with switching via the switching input**

- After passing a permanent magnet in the rails no action is activated.  
Possible cause: The reed contact or the Hall sensor has been mounted incorrectly. → Check the connections.  
  
Possible cause: The distance to the magnet is too large or the magnet is too weak. → Alter the position of the magnet (if possible) or use a stronger one.  
  
Possible cause: The magnet has been mounted incorrectly polarized.  
→ Alter the mounting direction.  
  
Possible cause: The assignment of the function to the switching input is wrong or the minimum switch-on time is too short. → Check the inputs in CV 62 and 97.

### **Problems in analogue mode**

- The decoder does not react in analogue mode.  
Possible cause: The analogue mode is switched off. → Alter the value for CV 29.
- The decoder does not switch to analogue mode (or switches over although it is still digitally controlled).  
Possible cause: The value in CV 11 is set too high or too low. → Alter the value and check the settings in operation.

**Hotline**

If problems with your decoder occur, our hotline is pleased to help you (mail address on the last page).

**Repairs**

You can send in a defective decoder for repair (address on the last page). In case of guarantee the repair is free of charge for you. With damages not covered by guarantee, the maximum fee for the repair is 50 % of the sales price according to our valid price list. We reserve the right to reject the repairing of a decoder when the repair is impossible for technical or economic reasons.

Please do not send in a decoder for repair charged to us. In case of warranty we will reimburse the forwarding expenses up to the flat rate we charge according to our valid price list for the delivery of the product. With repairs not covered by guarantee you have to bear the expenses for sending back and forth.

## 10. Guarantee bond

For this product we issue voluntarily a guarantee of 2 years from the date of purchase by the first customer, but in maximum 3 years after the end of series production. The first customer is the consumer first purchasing the product from us, a dealer or another natural or juristic person reselling or mounting the product on the basis of self-employment. The guarantee exists supplementary to the legal warranty of merchantability due to the consumer by the seller.

The warranty includes the free correction of faults which can be proved to be due to material failure or factory flaw. With kits we guarantee the completeness and quality of the components as well as the function of the parts according to the parameters in not mounted state. We guarantee the adherence to the technical specifications when the kit has been assembled and the ready-built circuit connected according to the manual and when start and mode of operation follow the instructions.

We retain the right to repair, make improvements, to deliver spares or to return the purchase price. Other claims are excluded. Claims for secondary damages or product liability consist only according to legal requirements.

Condition for this guarantee to be valid, is the adherence to the manual. In addition, the guarantee claim is excluded in the following cases:

- if arbitrary changes in the circuit are made,
- if repair attempts have failed with a ready-built module or device,
- if damaged by other persons,
- if damaged by faulty operation or by careless use or abuse.

## 11. EU Declaration of Conformity

 This product fulfils the requirements of the following EU directives and therefore bears the CE marking.

2001/95/EU Product Safety Directive

2015/863/EU on the restriction of the use of certain hazardous substances in electrical and electronic equipment (RoHS)

2014/30/EU on electromagnetic compatibility (EMC Directive).  
Underlying standards:

DIN-EN 55014-1 and 55014-2: Electromagnetic compatibility - Requirements for household appliances, electric tools and similar electrical appliances. Part 1: Emitted interference, Part 2: Immunity to interference

To maintain electromagnetic compatibility during operation, observe the following measures:

Only connect the supply transformer to a professionally installed and fused earthed socket.

Do not make any changes to the original components and follow the instructions, connection and assembly diagrams in this manual exactly.

Only use original spare parts for repair work.

## 12. Declarations concerning the WEEE directive



This product complies with the requirements of the EU Directive 2012/19/EC on Waste Electrical and Electronic Equipment (WEEE).

Do not dispose of this product in (unsorted) municipal waste, but recycle it.

### 13. The asterisks \*\*

This manual mentions the following companies:

Gebr. MÄRKLIN & Cie. GmbH | Stuttgarter Str. 55-57 | D-73033 Göppingen



Information and tips:

<http://www.tams-online.de>

Warranty and service:

Tams Elektronik GmbH

Fuhrberger Straße 4

DE-30625 Hannover

fon: +49 (0)511 / 55 60 60

fax: +49 (0)511 / 55 61 61

e-mail: [modellbahn@tams-online.de](mailto:modellbahn@tams-online.de)

