

# WD-34 | WD-34.2 | WD-34.M

4-fold Turnout Decoder

MM

DCC

## Manual

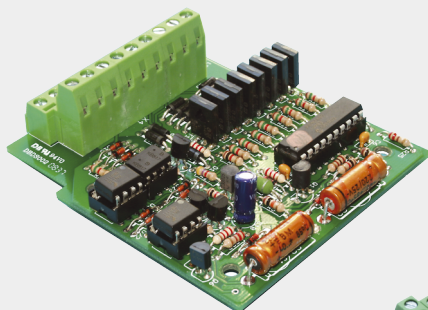

### WD-34

Item numbers

43-02345

43-02346

43-02347

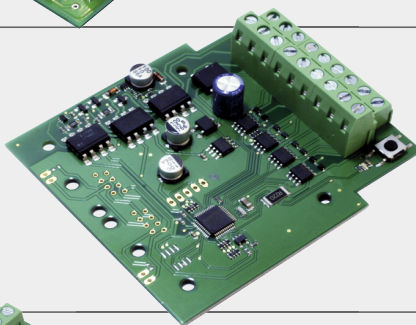

### WD-34.2

Item numbers

43-02356

43-02357

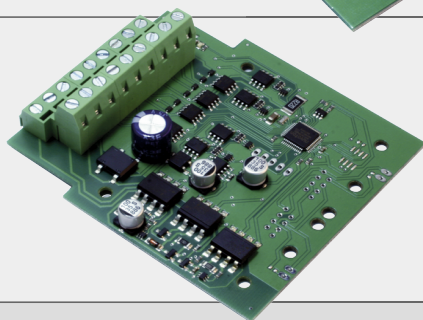

### WD-34.M

Item numbers

43-02366

43-02367

**Version: 3.0 | Status: 07/2023**

**© Tams Elektronik GmbH**

All rights reserved, in particular the right of reproduction, distribution and translation. Copies, reproductions and alterations in any form require the written permission of Tams Elektronik GmbH. We reserve the right to make technical changes.

**Printing the manual**

The formatting is optimised for double-sided printing. The standard page size is DIN A5. If you prefer a larger display, printing on DIN A4 is recommended.

**Notes on RailCom®**

RailCom® is a German trademark registered in the name of Lenz Elektronik for class 9 "Electronic Controls" under number 301 16 303 and a trademark registered for classes 21, 23, 26, 36 and 38 "Electronic Controls for Model Railways" in U.S.A. under Reg.No. 2,746,080. To enhance the readability of the text, we have refrained from referring to the term each time it is used.

## Contents

1. Getting started.....	4
1.1. Contents of the package.....	4
1.2. Accessories.....	4
1.3. Intended use.....	5
1.4. Safety instructions.....	5
2. Operation overview.....	6
3. Assembling the WD-34 kit.....	8
3.1. Safety instructions.....	8
3.2. Soldering properly.....	9
3.3. Preparation.....	10
3.4. WD-34: PCB layout and parts list.....	12
3.5. Assembly.....	14
3.6. Performing a visual check.....	15
4. Connections.....	16
4.1. Pin connections accessory decoder WD-34.....	17
4.2. Pin connections accessory decoder WD-34.2.....	18
4.3. Pin connections accessory decoder WD-34.M.....	19
4.4. Connection to the power supply.....	20
4.5. Connection examples.....	21
5. Settings.....	22
5.1. Setting the addresses.....	22
5.2. Basic settings.....	24
5.3. Configuration data.....	24
6. Checklist for troubleshooting and error correction.....	26
6.1. Technical Hotline.....	27
6.2. Repairs.....	27
7. Technical data.....	28
8. Warranty, EU conformity & WEEE.....	30
8.1. Guarantee bond.....	30
8.2. EU Declaration of Conformity.....	31
8.3. Declarations on the WEEE Directive.....	31

## 1. Getting started

The instructions will help you step by step with the safe and proper assembly of the kit and installation and use of your turnout decoder. Before you start to assemble the kit or put the decoder into operation, read this manual completely, especially the safety instructions and the section on possible errors and their elimination. You will then know what you have to pay attention to and thus avoid errors that sometimes can only be rectified with a lot of effort.

Keep the instructions in a safe place so that you can restore functionality later in the event of any malfunctions. If you pass the turnout decoder on to another person, also give the instructions with it.

### 1.1. Contents of the package

#### **Turnout decoder WD-34:**

- 1 kit WD-34 (item no. 43-02345-01), containing the components listed in the parts list (→ section 3.4.) and one PCB or  
1 ready-built and tested circuit board WD-34 (item no. 43-02346-01) or  
1 turnout decoder WD-34 in housing (item no. 43-02347-01)
- one jumper for programming the address

#### **Turnout decoder WD-34.2:**

- 1 ready-built and tested circuit board WD-34.2 (item no. 43-02356-01) or  
1 turnout decoder WD-34.2 in housing (item no. 43-02357-01)

#### **Turnout decoder WD-34.M:**

- 1 ready-built and tested circuit board WD-34.M (item no. 43-02366-01) or  
1 turnout decoder WD-34.M in housing (item no. 43-02367-01)

### 1.2. Accessories

#### **To assemble the kit you will need**

- a soldering iron with temperature control and a thin tip and a deposit stand or a controlled soldering station
- a scraper, rag or sponge
- a heat-resistant pad
- a small pair of side cutters and wire strippers
- tweezers and flat-nose pliers if necessary
- electronic solder (preferably 0.5 to 0.8 mm diameter)

#### **Connection cables**

The use of stranded wire is recommended for making the connections. Stranded wires consist of several thin individual wires and are therefore more flexible than rigid wires with the same copper cross-section. Recommended cross-sections:

- for all connections:  $\geq 0.25 \text{ mm}^2$

### Indicator LED for WD-34.2

If you want to indicate problems when switching end-switched turnouts, you need an LED. A series resistor is not required.

### Use of turnouts with motor drive at WD-34 and WD-34.2:

When using turnouts with motor drive on the turnout decoders WD-34 and WD-34.2 you need an adapter AMW:

- with WD-34: AMW-2 (item-no. 72-00086)
- with WD-34.2: AMW-1 (item-no. 72-00076).

### 1.3. Intended use

The turnout decoder is intended for use in model construction, especially in model railway layouts, according to the specifications in the manual. Any other use is not in accordance with the intended use and will result in the loss of the warranty claim. Intended use also includes reading, understanding and following all parts of the instructions. The turnout decoder is not intended to be used by children under the age of 14.

### 1.4. Safety instructions



#### Note:

The turnout decoder contains integrated circuits (ICs). These are sensitive to electrostatic charging. Therefore, do not touch these components until you have "discharged" yourself. For this purpose, e.g. a grip on a radiator is sufficient.

Improper use and non-observance of the instructions can lead to incalculable hazards. Prevent these dangers by carrying out the following measures:

- Only use the turnout decoder in closed, clean and dry rooms. Avoid moisture and splash water in the environment. After condensation has formed, wait two hours for acclimatisation before use.
- Disconnect the decoder from the power supply before carrying out wiring work.
- Supply the decoder only with extra-low voltage as specified in the technical data. Use only tested and approved transformers.
- Only plug the mains plugs of transformers into properly installed and fused earthed sockets.
- When making electrical connections, ensure that the cable cross-section is sufficient.
- Heating of the decoder during operation is normal and harmless.
- Do not expose the decoder to high ambient temperatures or direct sunlight. Observe the information on the maximum operating temperature in the technical data.
- Regularly check the operational safety of the decoder, e.g. for damage to the connection cables.
- If you notice damage or if malfunctions occur, disconnect the connection to the power supply immediately. Send the decoder in for inspection.

## 2. Operation overview

The turnout decoders WD-34, WD-34.2 and WD-34.M are designed to control accessories, activated by a short switching impulse. So, it is possible to switch as well accessories with as without tape shut-off. Examples of use:

		WD-34	WD-34.2	WD-34.M
Solenoid accessories	Coil driven turnouts	X	X	X
	Semaphore signals with twin coil drive	X	X	X
	Decouplers	X	X	X
Motor driven turnouts		AMW-2 required	AMW-1 required	X

With one turnout decoder you can control a maximum of:

- four turnouts or semaphores with twin coil drive or
- eight other solenoid accessories or
- four motor driven turnouts.

It is possible to connect a different types of accessories to the four pairs of outputs.

### Driving the decoder via accessory decoder commands

The outputs of the decoders are operated via accessory decoder commands in DCC or Motorola format, sent from the central unit to one of the four turnout addresses. The decoders automatically recognize the commands' data format. It is possible to switch the outputs via mixed DCC and Motorola commands as well as to operate one output alternately in DCC and Motorola format.

### Operation via vehicle decoder commands (WD-34.2 and WD-34.M only)

You can use a vehicle decoder address (locomotive address) to operate the turnout decoders WD-34.2 and WD-34.M instead of turnout addresses. The 4 outputs of the decoder are switched via the function keys F1 to F4 then. This allows to use the WD-34.2 and WD-34.M in combination with DCC control units not designed for controlling turnout addresses. Note: The changeover to the use of locomotive addresses is only possible with a DCC control unit.

### Programming

Using a DCC central unit, the decoder address and the decoder's features can be defined by programming the configuration variables (CV). It is also possible to set the address by using a programming jumper (WD-34) or a push-button switch (WD-34.2 and WD-34.M).

When using a Motorola central unit the address has to be set with a programming jumper (WD-34) or a push-button switch (WD-34.2 and WD-34.M). Changing the other decoder's features or assigning a locomotive address is neither necessary nor possible in layouts run in Motorola format only.

**Feedback via RailCom®** (according to RCN-217)

The turnout decoders are RailCom compatible, i.e. the decoders are able to pass the RailCom messages via the rails to special RailCom detectors. This allows e.g. to feedback the correct performance of setting and switching commands or the actual setting of turnouts.

**Feedback of a wrong position of turnouts (WD-34.2 only)**

After the set switching time ("on-time"), the turnout decoder WD-34.2 compares the actual position of turnouts with limit stop with the position it should have according to the digital commands. If the position does not match, e.g. because

- a mechanical problem has occurred or
- the turnout has been switched manually

the fault can be displayed at an external LED (LED not included in the package). The flashing sequence shows the turnout in question.

**Short-circuit protection**

In case a short-circuit occurs while switching a connected accessory, the decoder stops the switching operation and the LED on the PCB starts to flash quickly.

**Power supply**

The turnout decoders and the connected accessories can be supplied

- either with digital voltage from the booster circuit, i.e. via the integrated booster of the digital central unit or a separate booster,
- or via its own transformer to relieve the digital circuit.

### 3. Assembling the WD-34 kit

You can skip this section if you have purchased a ready-built decoder or device.

#### 3.1. Safety instructions

##### **Mechanical hazards**

Cut wires can have sharp ends and can cause serious injuries. Watch out for sharp edges when you pick up the PCB.

Visibly damaged parts can cause unpredictable danger. Do not use damaged parts: recycle and replace them with new ones.

##### **Fire risk**

Touching flammable material with a hot soldering iron can cause fire, which can result in injury or death through burns or suffocation. Connect your soldering iron or soldering station only when actually needed. Always keep the soldering iron away from inflammable materials. Use a suitable soldering iron stand. Never leave a hot soldering iron or station unattended.

##### **Thermal danger**

A hot soldering iron or liquid solder accidentally touching your skin can cause skin burns. As a precaution:

- use a heat-resistant mat during soldering,
- always put the hot soldering iron in the soldering iron stand,
- point the soldering iron tip carefully when soldering, and
- remove liquid solder with a thick wet rag or wet sponge from the soldering tip.

##### **Dangerous environments**

A working area that is too small or cramped is unsuitable and can cause accidents, fires and injury. Prevent this by working in a clean, dry room with enough freedom of movement.

##### **Other dangers**

Children can cause any of the accidents mentioned above because they are inattentive and not responsible enough. Children under the age of 14 should not be allowed to work with this kit or the ready-built device.



##### **Caution:**

Little children can swallow small components with sharp edges, with fatal results! Do not allow components to reach small children.

In schools, training centres, clubs and workshops, assembly must be supervised by qualified personnel. In industrial institutions, health and safety regulations applying to electronic work must be adhered to.



### 3.2. Soldering properly

- Use a soldering iron with temperature control, which you set to approx. 300 °C.
- Only use electronic solder with a flux.
- Never use soldering water or soldering grease when soldering electronic circuits. These contain an acid that destroys components and conductor paths.
- Insert the connecting wires of the components as far as possible through the holes of the board without using force. The body of the component should be close above the board.
- Make sure that the polarity of the components is correct before soldering them.
- Solder quickly: soldering for too long can cause pads or tracks to become detached or even destroy components.
- Hold the soldering tip on the soldering point in such a way that it touches the component wire and the pad at the same time. Add (not too much) solder simultaneously. As soon as the solder begins to flow, remove it from the soldering point. Then wait a moment for the solder to flow well before removing the soldering iron from the soldering joint.
- Do not move the component you have just soldered for about 5 seconds.
- A clean, non-oxidised (scale-free) soldering tip is essential for a perfect soldering joint and good soldering. Therefore, before each soldering, wipe off excess solder and dirt with a damp sponge, a thick damp cloth or a silicone wiper.
- After soldering, cut off the connecting wires directly above the soldering point with a side cutter.
- After assembly, always check each circuit again to ensure that all components are correctly inserted and polarised. Also check that no connections or tracks have been accidentally bridged with tin. This can lead not only to malfunction, but also to the destruction of expensive components. You can re-liquefy excess solder with the clean hot soldering tip. The solder then flows from the board to the soldering tip.

### 3.3. Preparation

Put the sorted components in front of you on your workbench.

The separate electronic components have the following special features you should take into account in assembling:

#### Resistors

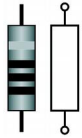

Resistors reduce current.

The value of resistors for smaller power ratings is indicated through colour rings. Every colour stands for another figure. Carbon film resistors have 4 colour rings. The 4th ring (given in brackets here) indicates the tolerance of the resistor (gold = 5 %, silver = 10 %).

Value:

0,27  $\Omega$

Colour rings:  
red - violet - silver (gold)

33  $\Omega$

orange – orange – black (gold)

100  $\Omega$

brown - black - brown (gold)

220  $\Omega$

red - red - brown (gold)

1 k $\Omega$

brown - black - red (gold)

1,5 k $\Omega$

brown - green - red (gold)

2,2 k $\Omega$

red - red - red (gold)

4,7 k $\Omega$

yellow - violet - red (gold)

10 k $\Omega$

brown - black - orange (gold)

#### Ceramic capacitors



Among other things ceramic capacitors are used for filtering interference voltages or as frequency determining parts. Ceramic capacitors are not polarized.

Normally they are marked with a three-digit number which indicates the value coded. The number 104 corresponds to the value 100 nF.

#### Electrolytic capacitors

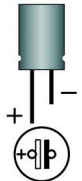

Electrolytic capacitors are often used to store energy. In contrast to ceramic capacitors they are polarized. The value is given on the casing.

Electrolytic capacitors are available with different voltage sustaining capabilities. Using an electrolytic capacitor with a voltage sustaining capability higher than required is always possible.

#### Diodes and Zener diodes

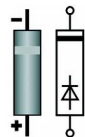

Diodes allow the current to pass through in one direction only (forward direction), simultaneously the voltage is reduced by 0,3 to 0,8 V. Exceeding of the limit voltage always will destroy the diode, and allow current to flow in the reverse direction.

Zener diodes are used for limiting voltages. In contrast to "normal" diodes they are not destroyed when the limit voltage is exceeded.

The diode type is printed on the body.

## Light emitting diodes (LEDs)

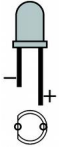

When operated in the forward direction the LEDs light. They are available in several different versions (differing in colour, size, form, luminosity, maximum current, voltage limits).

Light emitting diodes should always be connected via a series resistor which limits the current and prevents failure.

## Transistors



Transistors are current amplifiers which convert low signals into stronger ones. There are several types in different package forms available. The type designation is printed on the component.

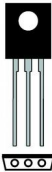

Transistors for a low power rating (e.g. BC types) have a package in form of a half cylinder (SOT-Gehäuse). Transistors for a high power rating (e.g. BD types) have a flat package (TO-package), which is in use in different versions and sizes. The three pins of bipolar transistors (e.g. BC and BD types) are called basis, emitter and collector (abbreviated with the letters B, E, C in the circuit diagram).

## Integrated circuits (ICs)



Depending on the type, ICs fulfil various tasks. The most common housing form is the so-called "DIL"-housing, from which 4, 6, 8, 14, 16, 18 or more "legs" (pins) are arranged along the long sides.

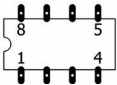

ICs are sensitive to damage during soldering (heat, electrostatic charging). For that reason in the place of the ICs IC sockets are soldered in, in which the ICs are inserted later.

## Microcontrollers

Microcontrollers are ICs, which are individually programmed for the particular application. The programmed controller are only available from the manufacturer of the circuit belonging to it.

## Opto couplers

Opto couplers are ICs, which work similar to laser beam switches. They combine in one housing a light emitting diode and a photo transistor. Their task is the transmission of information without galvanic connection. They are in a DIL-housing with at least 4 pins.

## Modular terminal blocks

Modular terminal blocks are solder-in screw-type terminals. They provide a solder-free and safe connection of the cables to the circuit, which can still be separated any time.

### 3.4. WD-34: PCB layout and parts list

#### PCB layout

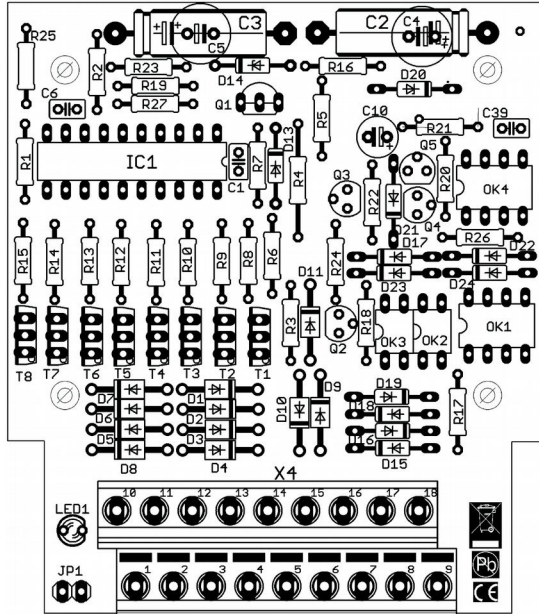

**Parts list**

Carbon film resistors 0,25 W	R20, R26	33 $\Omega$
	R18, R27	100 $\Omega$
	R23, R25	220 $\Omega$
	R6, R19, R22	1 k $\Omega$
	R8, R9, R10, R11, R12, R13, R14, R15, R17	1,5 k $\Omega$
	R1, R3, R7	2,2 k $\Omega$
	R21, R24	4,7 k $\Omega$
	R2, R5, R16	10 k $\Omega$
Wire resistors 1 W	R4	0,27 $\Omega$
Ceramic capacitors	C1, C6, C39	100 nF
Electrolytic capacitors	C10	100 $\mu$ F/25V
	C2, C3 (radial) or C4, C5 (axial)	220 $\mu$ F/25V
Diodes	D1, D2, D3, D4, D5, D6, D7, D8, D9, D10, D11	1N400x, x=2...7
	D15, D16, D17, D18, D19, D21, D22, D23, D24	1N4148
Zener diodes	D13, D20	ZPD5V1
	D14	ZPD47V
LEDs	LED1	LED 3mm
Transistors for a low power rating	Q2	BC327
	Q3	BC337
	Q1, Q4, Q5	BC557B
Transistors for a high power rating	T1, T2, T3, T4, T5, T6, T7, T8	BD680
Microcontrollers	IC1	PIC16F690P
Opto couplers	OK1, OK4	6N136
	OK2, OK3	PC817 (2 pieces) or PC827 (1 piece)
IC-sockets	IC1	20-pole
	OK1, OK4, OK2/OK3	8-pole
Double modular terminal blocks	X4	2 x 9-pole
Pin header	JP1	2-pole

### 3.5. Assembly

Proceed according to the order given in the list below. First solder the components on the solder side of the PCB and then cut the excess wires with the side cutter. Follow the instructions on soldering in section 3.

**⚠ Caution:** Several components have to be mounted according to their polarity. When soldering these components the wrong way round, they can be damaged when you connect the power. In the worst case the whole circuit can be damaged. At the best, a wrongly connected part will not function.

1.	Resistors (except R4)	Mounting orientation of no importance.
2.	Diodes, Zener diodes	Observe the polarity! The negative end of the diodes is marked with a ring. This is shown in the PCB layout.
3.	Ceramic Capacitors	Mounting orientation of no importance.
4.	Resistor R4	
5.	IC sockets	Mount the sockets that way, the marking on the sockets show in the same direction as the markings on the PCB board.
6.	Light emitting diodes (LEDs)	Observe the polarity! With wired LEDs the longer lead is always the anode (positive pole).
7.	Transistors for a low power rating	Observe the polarity! The cross section of transistors for a low power rating in SOT-packages is shown in the PCB layout.
8.	Pin header	
9.	Transistors for a high power rating	Observe the polarity! With transistors for a high power rating in TO packages (e.g. BD types) the unlabelled back side is marked in the PCB layout by a thick line.
10.	Electrolytic capacitors	Observe the polarity! One of the two leads (the shorter one) is marked with a minus sign.
11.	Double modular terminal blocks	Put together the terminal blocks before mounting them.
12.	ICs in DIL-housing	Insert the ICs into the soldered socket. Do not touch the ICs without first discharging yourself by touching a radiator or other grounded metal parts. Do not bend the "legs" when inserting them into the sockets. Check that the markings on the PCB, the socket and the IC show to the same direction.

### 3.6. Performing a visual check

Perform a visual check after the assembly of the decoder and remove faults if necessary:

- Remove all loose parts, wire ends or drops of solder from the PCB. Remove all sharp wire ends.
- Check that solder contacts which are close to each other are not unintentionally connected to each other. Risk of short circuit!
- Check that all components are polarised correctly.

When you have remedied all faults, go on to the next part.

### 4. Connections

The decoder is equipped with terminals into which you plug and screw the connecting cables for the solenoid accessories and the power supply.

Make the connections one after the other:

- the accessories (e.g. turnouts)
- the central unit
- the power supply

#### Turnout decoder WD-34

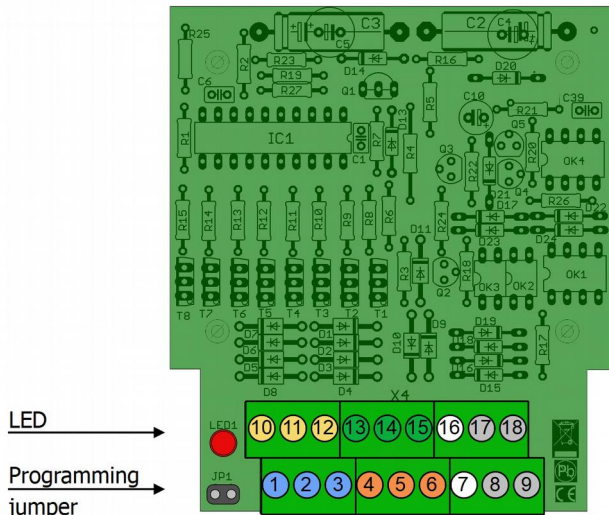

#### Turnout decoders WD-34.2 and WD-34.M

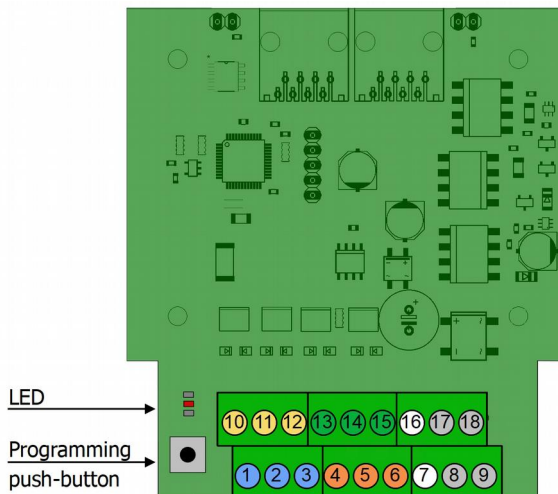



## 4.1. Pin connections accessory decoder WD-34

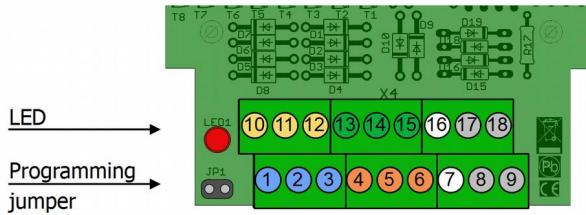

<b>Turnout decoder WD-34</b>	
1	Solenoid accessory / turnout 2 "straight"
2	Solenoid accessory / turnout 2 return conductor
3	Solenoid accessory / turnout 2 "diverging"
4	Solenoid accessory / turnout 4 "straight"
5	Solenoid accessory / turnout 4 return conductor
6	Solenoid accessory / turnout 4 "diverging"
7	not in use
8	Power supply / transformer (~)
9	Input DCC signal / central unit
10	Solenoid accessory / turnout 1 "straight"
11	Solenoid accessory / turnout 1 return conductor
12	Solenoid accessory / turnout 1 "diverging"
13	Solenoid accessory / turnout 3 "straight"
14	Solenoid accessory / turnout 3 return conductor
15	Solenoid accessory / turnout 3 "diverging"
16	not in use
17	Power supply / transformer (~)
18	Input DCC signal / central unit

## 4.2. Pin connections accessory decoder WD-34.2

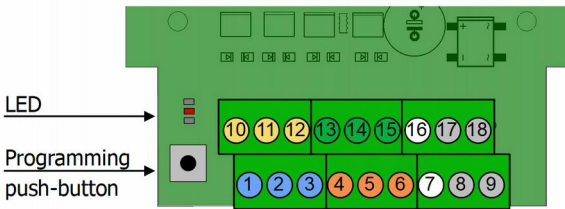

<b>Turnout decoder WD-34.2</b>	
1	Solenoid accessory / turnout 2 "diverging" or F2 = "on"
2	Solenoid accessory / turnout 2 return conductor
3	Solenoid accessory / turnout 2 "straight" or F2 = "off"
4	Solenoid accessory / turnout 4 "diverging" or F4 = "on"
5	Solenoid accessory / turnout 4 return conductor
6	Solenoid accessory / turnout 4 "straight" or F4 = "off"
7	external LED (-)
8	Power supply / transformer (~)
9	Input DCC signal / central unit
10	Solenoid accessory / turnout 1 "diverging" or F1 = "on"
11	Solenoid accessory / turnout 1 return conductor
12	Solenoid accessory / turnout 1 "straight" or F1 = "off"
13	Solenoid accessory / turnout 3 "diverging" or F3 = "on"
14	Solenoid accessory / turnout 3 return conductor
15	Solenoid accessory / turnout 3 "straight" or F3 = "off"
16	external LED (+). A series resistor is not required.
17	Power supply / transformer (~)
18	Input DCC signal / central unit

### 4.3. Pin connections accessory decoder WD-34.M

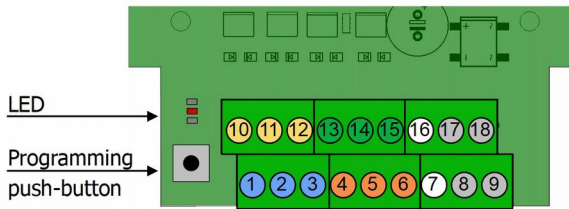

Turnout decoder WD-34.M		
	Motor-run turnouts	Solenoid accessories
1	Motor-run turnout 2 connection 1 or F2 = "on"	Solenoid accessory / turnout 2 "diverging" or F2 = "on"
2	not in use	Solenoid accessory / turnout 2 return conductor
3	Motor-run turnout 2 connection 2 or F2 = "off"	Solenoid accessory / turnout 2 "straight" or F2 = "off"
4	Motor-run turnout 4 connection 1 or F4 = "on"	Solenoid accessory / turnout 4 "diverging" or F4 = "on"
5	not in use	Solenoid accessory / turnout 4 return conductor
6	Motor-run turnout 4 connection 2 or F4 = "off"	Solenoid accessory / turnout 4 "straight" or F4 = "off"
7	not in use	
8	Power supply / transformer (~)	
9	Input DCC signal / central unit	
10	Motor-run turnout 1 connection 1 or F1 = "on"	Solenoid accessory / turnout 1 "diverging" or F1 = "on"
11	not in use	Solenoid accessory / turnout 1 return conductor
12	Motor-run turnout 1 connection 2 or F1 = "off"	Solenoid accessory / turnout 1 "straight" or F1 = "off"
13	Motor-run turnout 3 connection 1 or F3 = "on"	Solenoid accessory / turnout 3 "diverging" or F3 = "on"
14	not in use	Solenoid accessory / turnout 3 return conductor
15	Motor-run turnout 3 connection 2 or F3 = "off"	Solenoid accessory / turnout 3 "straight" or F3 = "off"
16	not in use	
17	Power supply / transformer (~)	
18	Input DCC signal / central unit	

### 4.4. Connection to the power supply

You can supply the decoder and the connected servos and other consumers

- either with the digital voltage from the booster circuit, i.e. via the integrated booster of the digital central unit or a separate booster,
- or if you want to relieve the digital circuit, via your own transformer.

7	not in use	<p><b>! Caution:</b> If a component gets too hot, disconnect the decoder and the power supply from the mains <b>immediately</b>. Possible short circuit! Check the assembly!</p>
8	Power supply / transformer (~)	
9	Input DCC signal / central unit	
16	not in use	
17	Power supply / transformer (~)	
18	Input DCC signal / central unit	

#### Power supply via central unit

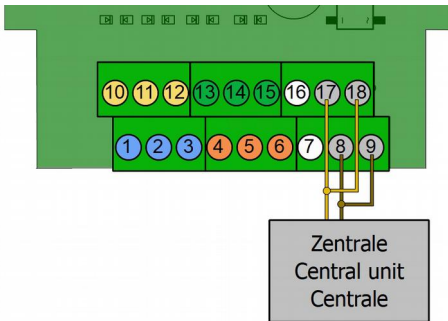

**! Caution:**  
Switch off the control unit before connecting the decoder.

#### Power supply via separate transformer

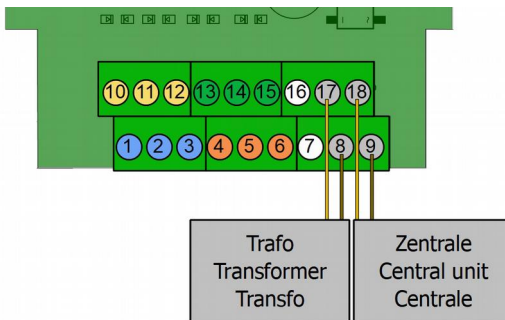

**! Caution:**  
When connecting several devices to the same voltage supply, generally all connections have to be polarised identically. Otherwise a short circuit will occur, possibly damaging connected devices.

### 4.5. Connection examples

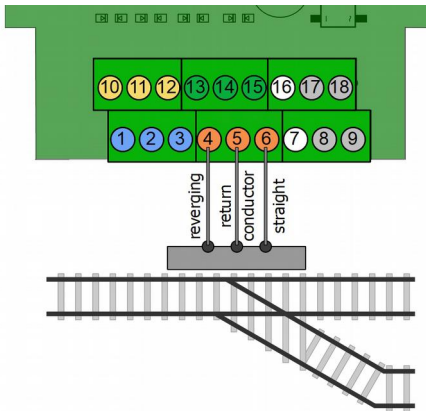

**Connection example:  
Coil driven turnouts**

Connection of turnouts to terminals 4 to 6 ("turnout 4")

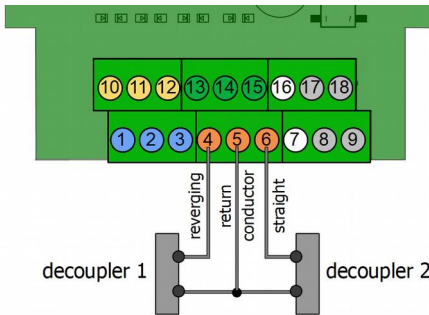

**Connection example:  
Decouplers**

Connection of two decouplers to terminals 4 to 6

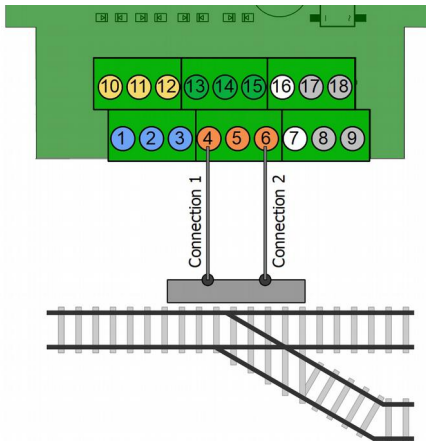

**Connection example:  
Motor driven turnouts to  
WD-34.M**

Connection of turnouts to terminals 4 and 6 ("turnout 4")

## 5. Settings

You can program the configuration variables (CV) using a DCC digital central unit. See the chapter in the manual of your central unit where the byte wise programming of configuration variables (CVs) is explained.

When using a Motorola central unit you can set the decoder address with a programming jumper (WD-34) or with a programming push-button (WD-34.2 and WD-34.M). Changing the other decoder's features or assigning a locomotive address is neither necessary in layouts run in Motorola format only nor possible with Motorola central units.

### 5.1. Setting the addresses

You can set the decoder address either by programming the CVs with your DCC central unit or by using the programming jumper or push-button. When setting the decoder address it is of no importance if you intend to operate the decoder by vehicle decoder commands (locomotive commands) or accessory decoder commands (turnout commands).

#### Setting the address with the jumper or push-button

With Motorola central units the address can be set via the programming jumper (WD-34) or the programming push-button (WD-34.2 and WD-34.M) only. When using DCC central units it is often easier to set the address via the programming jumper / push-button than to program it via CV.

Hint: Setting the address via the jumper / push-button is impossible unless the decoder is operated by turnout addresses. When the operation via locomotive addresses is set in CV29, it is impossible to set the address with the jumper/push-button.

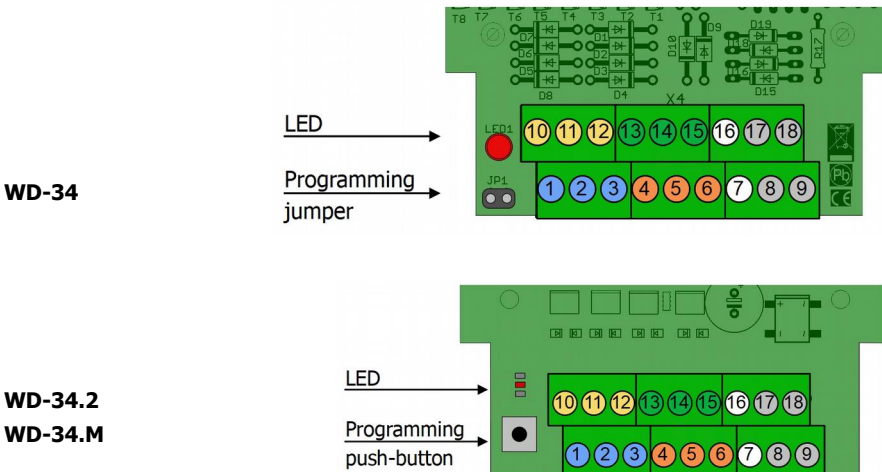

In order to set the address via the programming jumper / push-button perform the following steps:

1. **WD-34:** Bridge the two pins of the programming connector JP1, by putting on the jumper included in the package. Take it away as soon as the LED flashes.  
**WD-34.2 and WD-34.M:** Push the programming push-button on the PCB. The LED flashes.
2. Set one of the addresses from the quadruple accessory decoder address block you want to use for switching the connected accessories at the control unit (e.g. address "10" from the quadruple accessory decoder address block 9 – 12). Perform a switching command for the chosen address.
3. As soon as the LED goes out, the decoder has taken over the new address.

### Setting the decoder address via CVs

Instead of setting the address using the programming button, you can alternatively set it by programming the CVs with a DCC control unit. The turnout addresses, via which the switching commands are sent, result as follows:

Decoder address x 4 = highest address of the quadruple accessory decoder address block

Note: For the control of the decoder in Motorola format "255" is the highest decoder address (= turnout address 1020).

Note: With some control units the numbering of the turnout addresses does not start with "1" but with "0". The addresses assigned to an address block are shifted accordingly.

CV	No.	Input value (Default)	Remarks and tips
Decoder address "Base value"	9	0, 1, 2, 3, ... 7 (0)	The "base value" of the decoder address results from multiplying the input value by 256.
Decoder address "Additional value"	1	1, 2, 3, ... 63 (1)	The decoder address results from the addition of the "additional value" to the "basic value".

Value in CV9	0	1	2	3	4	5	6	7
→ Base value	0	64	128	192	256	320	384	448

Value in CV1	1...63	0...63	0...63	0...63	0...63	0...63	0...63	0...62
→ Address	1 ... 63	64 ... 127	128 ... 191	192 ... 255	256 ... 319	320 ... 383	384 ... 447	448 ... 510

## 5.2. Basic settings

Name of CVs	CV-no.	Input value (Default)	Remarks and tips
Version	7	---	Read only!
Manufacturer	8	(62)	Read only!
Reset	8	0 ... 255	Any input value restores the settings in state of delivery.

## 5.3. Configuration data

Name of CVs	CV-no.	Input value (Default)	Remarks and tips
On-Time → WD-34.2 and WD-34.M only			
On-time turnout 1	3	0, 1, 2 ... 255 (5)	In case the central unit sends a coil-off-signal, the on-time tallies with the minimal switching time. With central units not sending a coil-off-signal, the minimal switching time results from the duration of the switching impulse + on-time. For that reason the actual minimal switching time depends directly from the setting in CV33.
On-time turnout 2	4	0, 1, 2 ... 255 (5)	
On-time turnout 3	5	0, 1, 2 ... 255 (5)	
On-time turnout 4	6	0, 1, 2 ... 255 (5)	
Configuration data 1 → WD-34	29	128, 136 (136)	RailCom off 128 RailCom on 136
Configuration data 1 → WD-34.2 → WD-34.M	29	0, 8, 128, 136 (136)	RailCom off 0 RailCom on 8 Operation via turnout addresses 0 locomotive addresses 128
Advice: When RailCom is not used it is recommended to switch it off in CV29.			



Name of CVs	CV-no.	Input value (Default)	Remarks and tips
Configuration data 2	33	0, 1, 2, 3 (0)	The input value has to be calculated by adding the numerical values assigned to the desired parameters.
			RailCom check on 0
			RailCom check off 1
			Central unit does not send coil-off 0 Central unit sends Coil-off 2

In standard operation the decoder checks directly after having been switched on if the booster for the connected section supplies a RailCom cutout. In case faulty detections are mounting the RailCom check should be switched off. This has no effect on the feedback with RailCom.

The central unit sending a coil-off-signal or not has direct effects on the on-time (see CV3 to 6). In order to set the minimal switching time properly, it is important to set in CV33 if the central unit in use sends this signal or not.

Examples for central unit **not** sending a coil-off-signal: Intellibox from Uhlenbrock, central units from Lenz.

Examples for central unit sending a coil-off-signal: MasterControl, RedBox and MasterControl.2 from Tams.

## 6. Checklist for troubleshooting and error correction

### **Warning:**

If you notice a strong heat development, immediately disconnect the connection to the supply voltage. **Fire hazard!**

Possible causes:

- One or more connections are faulty. → Check the connections.
- "Kit" version: one or more components are soldered incorrectly. → Carry out a visual inspection (→ section 3.5.) and eliminate the faults, if necessary.
- The decoder is defective. → Send the decoder in for inspection.

### **No reaction of the decoder**

Possible causes:

- The connection of the decoder to the central unit and / or the power supply is interrupted. → Check the connections.
- The connection of the decoder to the accessory or the turnout is interrupted. → Check the connections.
- The central unit is not operating. → Check if the central unit is ready for operation.
- The connected accessory or the connected turnout is defective. → Check the accessory or the turnouts.

### **No reaction of the decoder after programming**

Possible cause:

After programming the address the decoder does not react to switching commands.

Possible cause: When programming the decoder address via CV you set the decoder address. To switch the decoder accessory decoder addresses are used. → Input the accessory decoder address to switch. Advice: The decoder address multiplied with 4 tallies to the highest address from the quadruple accessory decoder address block.

Example: decoder address = 10 → corresponding accessory decoder addresses: 37 to 40



### **Flashing of the LED on the PCB**

Possible cause: Short circuit at one of the turnouts. → Check the turnouts.

### **Flashing of the external LED (WD-34.2 only)**

Cause: The assigned turnouts have not been switched properly or were switched manually. → Check the turnouts.

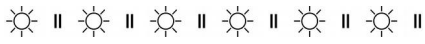
Assignment of the flashing sequences to the turnouts

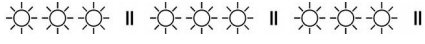
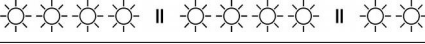
Turnout 1	1 x flashing – break	
Weiche 2	2 x flashing – break	
Weiche 3	3 x flashing – break	
Weiche 4	4 x flashing – break	

## 6.1. Technical Hotline

If you have any questions about the use of the decoder, our technical hotline will help you (telephone number and e-mail address on the last page).

## 6.2. Repairs

You can send us a defective decoder for inspection / repair (address on the last page). Please do not send us your return freight collect. In the event of a warranty or guarantee claim, we will reimburse you for the regular shipping costs.

### **Please enclose the following with your shipment**

- proof of purchase as evidence of any warranty or guarantee claim
- a brief description of the defect
- the address to which we should return the product(s)
- your email address and/or a telephone number where we can reach you in case of queries.

### **Costs**

The inspection of returned products is free of charge for you. In the event of a warranty or guarantee claim, the repair and return are also free of charge for you.

If there is no warranty or guarantee case, we will charge you the costs of the repair and the costs of the return. We charge a maximum of 50% of the new price for the repair according to our valid price list.

### **Carrying out the repair(s)**

By sending in the product(s), you give us the order to inspect and repair it. We reserve the right to refuse the repair if it is technically impossible or uneconomical. In the event of a warranty or guarantee claim, you will then receive a replacement free of charge.

### **Cost estimates**

Repairs for which we charge less than € 25.00 per item plus shipping costs will be carried out without further consultation with you. If the repair costs are higher, we will contact you and carry out the repair only after you have confirmed the repair order.

## 7. Technical data

### Digital protocols

Data formats	Motorola DCC (according to NMRA and RCN standard)
Address range Hint: The address range to be used also depends from the control unit.	WD-34: MM: 1020 turnout addresses DCC: 2040 turnout addresses  WD-34.2 and WD-34.M: MM: 1020 turnout addresses DCC: 2040 turnout addresses or 510 vehicle decoder addresses (locomotive addresses)
Feedback format	RailCom (according to RCN standard)

### Outputs

Number of outputs	8 (4 output pairs)
-------------------	--------------------

### Electrical properties

Power supply	Digital voltage of the booster circuit (12 - 24 volts) or 14 – 20 V a.c. voltage
Current consumption (without connected devices) approx.	WD-34: 40 mA WD-34.2 and WD-34.M: 60 mA
Maximum current per output	up to 2 seconds: 1,500 mA persistent: 800 mA

### Protection

Protection class	Ready-made module (without housing): IP 00 Meaning: No protection against foreign bodies, contact and water.  Ready device (in housing): IP 20 Meaning: Protected against solid foreign bodies with diameter $\geq 12.5$ mm and access with a finger. No protection against water.
------------------	--

---

**Environment**

---



For use in closed rooms

---

Ambient temperature during operation	0 ~ + 30 °C
--------------------------------------	-------------

---

Permissible relative humidity during operation	10 ~ 85% (non-condensing)
--	---------------------------

---

Ambient temperature during storage	- 10 ~ + 40 °C
------------------------------------	----------------

---

Permissible relative humidity during storage	10 ~ 85% (non-condensing)
--	---------------------------

---

**Other features**

---

Dimensions (approx.)	Circuit board: 72 x 82 mm Ready device including housing: 100 x 90 x 35 mm
----------------------	---

---

Weight (approx.)	WD-34: Assembled board (ready-made module): 58 g Ready device including housing: 106 g WD-34.2 and WD-34.M: Assembled board (ready-made module): 46 g Ready device including housing: 94 g
------------------	---

---

## 8. Warranty, EU conformity & WEEE

### 8.1. Guarantee bond

For this product we issue voluntarily a guarantee of 2 years from the date of purchase by the first customer, but in maximum 3 years after the end of series production. The first customer is the consumer first purchasing the product from us, a dealer or another natural or juristic person reselling or mounting the product on the basis of self-employment. The guarantee exists supplementary to the legal warranty of merchantability due to the consumer by the seller.

The warranty includes the free correction of faults which can be proved to be due to material failure or factory flaw. With kits we guarantee the completeness and quality of the components as well as the function of the parts according to the parameters in not mounted state. We guarantee the adherence to the technical specifications when the kit has been assembled and the ready-built circuit connected according to the manual and when start and mode of operation follow the instructions.

We retain the right to repair, make improvements, to deliver spares or to return the purchase price. Other claims are excluded. Claims for secondary damages or product liability consist only according to legal requirements.

Condition for this guarantee to be valid, is the adherence to the manual. In addition, the guarantee claim is excluded in the following cases:

- if arbitrary changes in the circuit are made,
- if repair attempts have failed with a ready-made module or device,
- if damaged by other persons,
- if damaged by faulty operation or by careless use or abuse.

## 8.2. EU Declaration of Conformity

 This product fulfils the requirements of the following EU directives and therefore bears the CE marking.

2001/95/EU Product Safety Directive

2015/863/EU on the restriction of the use of certain hazardous substances in electrical and electronic equipment (RoHS)

2014/30/EU on electromagnetic compatibility (EMC Directive). Underlying standards:

DIN-EN 55014-1 and 55014-2: Electromagnetic compatibility - Requirements for household appliances, electric tools and similar electrical appliances. Part 1: Emitted interference, Part 2: Immunity to interference

To maintain electromagnetic compatibility during operation, observe the following measures:  
Only connect the supply transformer to a professionally installed and fused earthed socket.  
Do not make any changes to the original components and follow the instructions, connection and assembly diagrams in this manual exactly.  
Only use original spare parts for repair work.

## 8.3. Declarations on the WEEE Directive

This product is subject to the requirements of the EU Directive 2012/19/EC on Waste Electrical and Electronic Equipment (WEEE), i.e. the manufacturer, distributor or seller of the product must contribute to the proper disposal and treatment of waste equipment in accordance with EU and national law. This obligation includes

- registration with the registering authorities ("registers") in the country where WEEE is distributed or sold
- the regular reporting of the amount of EEE sold
- the organisation or financing of collection, treatment, recycling and recovery of the products
- for distributors, the establishment of a take-back service where customers can return WEEE free of charge
- for producers, compliance with the Restriction of the Use of Certain Hazardous Substances in Electrical and Electronic Equipment (RoHS) Directive.



The "crossed-out wheeled bin" symbol means that you are legally obliged to recycle the marked equipment at the end of its life. The appliances must not be disposed of with (unsorted) household waste or packaging waste. Dispose of the appliances at special collection and return points, e.g. at recycling centres or at dealers who offer a corresponding take-back service.

---

Further Information and Tips:  
<http://www.tams-online.de>

Warranty and Service:  
**tams elektronik GmbH**

Fuhrberger Str. 4  
30625 Hannover / GERMANY

Phone: +49 (0)511 / 55 60 60

Fax: +49 (0)511 / 55 61 61

Email: [support@tams-online.de](mailto:support@tams-online.de)

