

S88-6

s88 Feedback Module
with additional ground connection
16-fold

Manual



Version: 1.0 | Status: 11/2022

© Tams Elektronik GmbH

All rights reserved, in particular the right of reproduction, distribution and translation. Copies, reproductions and alterations in any form require the written permission of Tams Elektronik GmbH. We reserve the right to make technical changes.

Printing the manual

The formatting is optimised for double-sided printing. The standard page size is DIN A5. If you prefer a larger display, printing on DIN A4 is recommended.

**** The asterisks**

The following manufacturers and their products are mentioned in this manual:

Gebr. MÄRKLIN & Cie. GmbH | Stuttgarter Straße 55-57 | DE-73033 Göppingen

ESU electronic solutions ulm GmbH & Co. KG | Edisonallee 29 | DE-89231 Neu-Ulm

Contents

1. Getting started.....	4
1.1. Contents of the package.....	4
1.2. Accessories.....	4
1.3. Intended use.....	4
1.4. Safety instructions.....	5
1.5. Care.....	5
2. Operation overview.....	6
2.1. Additional ground connection.....	6
2.2. Sending the feedback in the s88-bus.....	6
2.3. Connection to digital devices and other feedback devices.....	7
2.4. Info: Versions of the adapters S88-A.....	8
3. Connections S88-6.....	9
4. Checklist for troubleshooting and error correction.....	11
4.1. Technical Hotline.....	11
4.2. Repairs.....	11
5. Technical data.....	12
6. Warranty, EU conformity & WEEE.....	13
6.1. Guarantee bond.....	13
6.2. EU Declaration of Conformity.....	14
6.3. Declarations on the WEEE Directive.....	14

1. Getting started

The instructions will help you step by step with the safe and proper installation and use of your s88 feedback module. Before you put the feedback module into operation, read this manual completely, especially the safety instructions and the section on possible errors and their elimination. You will then know what you have to pay attention to and thus avoid errors that sometimes can only be rectified with a lot of effort.

Keep the instructions in a safe place so that you can restore functionality later in the event of any malfunctions. If you pass the feedback module on to another person, also give the instructions with it.

1.1. Contents of the package

- 1 ready-built and tested circuit board S88-6 (item no. 44-01606-01) or
1 s88 feedback module S88-6 in housing (item no. 44-01607-01)
- 1 patch cable (RJ 45)

1.2. Accessories

Connection cables

The use of stranded wire is recommended for making the connections. Stranded wires consist of several thin individual wires and are therefore more flexible than rigid wires with the same copper cross-section. Recommended cross-sections:

- Connections to the tracks: $\geq 0.25 \text{ mm}^2$

Connection to devices with 6-pole s88 interface

The feedback module has an additional connection for a 6-core cable for the connection of upstream feedback modules or digital devices (OUT connection), which can be used as an alternative to the RJ 45 connection. If conventional feedback modules with a 6-pole interface are to be connected downstream (IN connection), an S88-A adapter (see section 2.4.) is required.

1.3. Intended use

The s88 feedback module is intended for use in model railway layouts as specified in the instructions. Any other use is not in accordance with the intended use and will result in the loss of the warranty claim. Intended use also includes reading, understanding and following all parts of the instructions. The s88 feedback module is not intended to be used by children under the age of 14.

1.4. Safety instructions

**Note:**

The s88 feedback module contains integrated circuits (ICs). These are sensitive to electrostatic charging. Therefore, do not touch these components until you have "discharged" yourself. For this purpose, e.g. a grip on a radiator is sufficient.

Improper use and non-observance of the instructions can lead to incalculable hazards. Prevent these dangers by carrying out the following measures:

- Only use the s88 feedback module in closed, clean and dry rooms. Avoid moisture and splash water in the environment. After condensation has formed, wait two hours for acclimatisation before use.
- Disconnect the module from the power supply before carrying out wiring work.
- Supply the s88 feedback module only with extra-low voltage as specified in the technical data. Use only tested and approved transformers.
- Only plug the mains plugs of transformers into properly installed and fused earthed sockets.
- When making electrical connections, ensure that the cable cross-section is sufficient.
- Heating of the s88 feedback module during operation is normal and harmless.
- Do not expose the s88 feedback module to high ambient temperatures or direct sunlight. Observe the information on the maximum operating temperature in the technical data.
- Regularly check the operational safety of the s88 feedback module, e.g. for damage to the connection cables.
- If you notice damage or if malfunctions occur, disconnect the connection to the power supply immediately. Send the s88 feedback module in for inspection.

1.5. Care

Do not use any cleaning agents to clean the s88 feedback module. Only wipe the module dry. Disconnect the module from the power supply before cleaning.

2. Operation overview

The S88-6 feedback module is compatible with all components that work with the s88 bus developed by Märklin**. It can read in 16 ground contacts.

The S88-6 feedback module is optimised for use in centre conductor systems.

2.1. Additional ground connection

In feedback sections, the locomotive is supplied via the centre conductor and the continuous outer conductor. An interruption of the earth connection at the continuous rail (e.g. due to contamination) has an immediate effect on the running behaviour. In the worst case, the locomotive stops or does not start again after a stop in the feedback section.

The problem can be solved by connecting the two outer conductors by means of a diode. This so-called "diode trick" takes advantage of the fact that only one half-wave of the digital voltage can be used for the feedback in the s88 bus. By installing a diode, the other half-wave is "diverted" from the isolated to the continuous rail and thus an additional ground connection is established. With the s88-6, the diodes are integrated into the circuit, so that the time-consuming retrofitting of diodes is not necessary.

2.2. Sending the feedback in the s88-bus

The information is transmitted from the S88-6 via the s88-bus to the upstream feedback module or to the connected digital device (interface, memory or central unit). The data transmission from one feedback module to the other takes place in the s88 bus according to the bucket-chain-memory principle.

The number of feedback devices you can connect to a bus line depends on the interface, memory or central unit you use. Please observe the specifications of the device manufacturer.

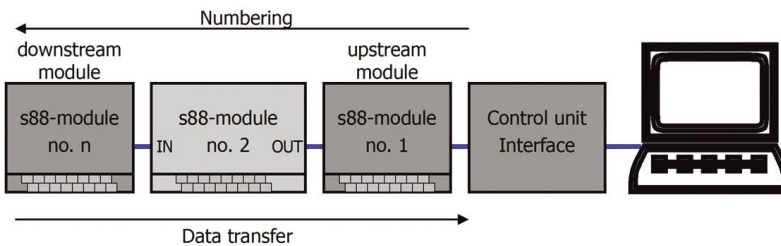

Addressing the feedback modules

The addressing of the S88-6 feedback module is done automatically according to its position in the bus line. It is therefore used in linear bus lines with direct connection to the interface, memory or central unit.

2.3. Connection to digital devices and other feedback devices



Info: Standard s88-N

The S88-6 has RJ-45 connectors according to the s88-N standard, which regulates the assignment of commercially available patch cables for use in s88 feedback systems. Unlike the commonly used 6-core connection cables, patch cables, which are common in computer networks, are largely shielded against foreign electrical signals. By using patch cables, the susceptibility to interference in the s88 bus is therefore considerably reduced.

Connection to digital devices or upstream s88 feedback modules

The S88-6 feedback module has two outputs (OUT) connected in parallel and can therefore be connected either via

- the 6-pole interface and a 6-core cable or
- the RJ 45 interface according to S88-N and a patch cable

to a digital device (interface, memory or central unit) or an upstream s88 feedback module.

Connection to downstream s88 feedback module

The input (IN) of the S88-6, via which the connection to a downstream s88 feedback module is established, is designed as an RJ 45 interface corresponding to S88-N. A patch cable is used for the connection to a downstream s88 feedback module with an s88-N interface at the output.

If a connection is to be made to an s88 feedback module with a 6-pin s88 interface, an additional S88-A adapter is required. Four different versions of the adapter are available, which differ in terms of

- connection (socket or plug) and
- mounting direction

Further information → Section 2.4.

2.4. Info: Versions of the adapters S88-A

S88 adapters with socket

can be plugged directly onto the 6-pin connector of an S88 back module.

Recommended use: Modules with connectors coming out from the side



S88-adapter with plug

are connected via a 6-core cable that is as short as possible (e.g. S88-15, item no. 44-09250-01). These adapters should always be used for the connection to the digital central unit in order to avoid mechanical damage to the S88 interface of the central unit.

Recommended use: digital devices, modules with connectors leading out upwards

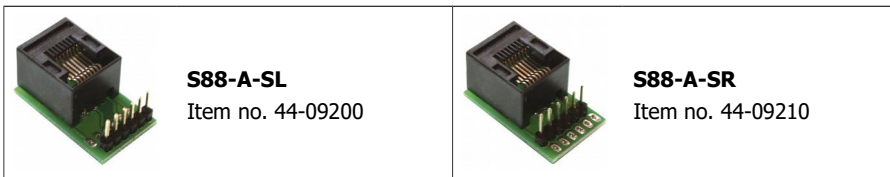

Mounting directions of the adapters S88-A

Depending on the installation direction, the "R" or "L" versions of the adapter are used.

Versions	Direction of the 6-pole connection*
S88-A-SL and S88-A-BL	Central unit
S88-A-SR and S88-A-BR	Feedback module

* Explanation: The specification refers to the direction in which the 6-pin connector of the adapter points.

Application examples



s88 module version 1: with connectors coming out from the side

s88 module version 2: with plugs protruding upwards

3. Connections S88-6

Pin assignment

IN	RJ-45 socket for the connection of a downstream s88 module
OUT	RJ-45 socket or 6-pole connector for the connection of an upstream s88 module or digital device
1 ... 16	Inputs for mass contacts
X2	Earth connection (if necessary)

Connection digital devices and s88 feedback modules

The S88-6 has two RJ-45 sockets (IN, OUT) to connect commercial Ethernet patch-cables (RJ-45 cables), which allow an interference free connection to other feedback modules or digital devices in accordance with the s88-N standard.

Use a 6-conductor connecting cable for the connection of digital devices or upstream customary feedback modules which you connect to the 6-pole connector of the S88-6. Alternatively you can use an adapter S88-A (optional extra) for the connection via a patch-cable.

To connect downstream feedback devices with 6-pin s88 connection, you need an adapter S88-A and, if necessary, a 6-pin ribbon cable (→ section 1.3.).

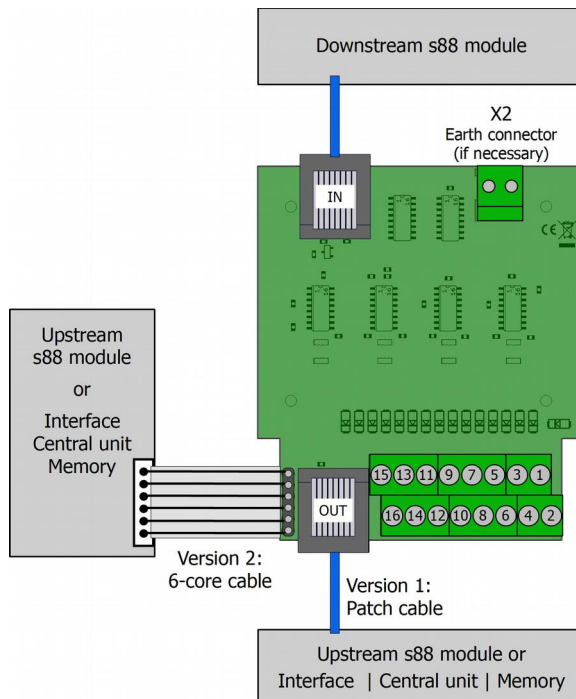

Earth connection

In systems with continuous mass (e.g. 3 rail systems fed with boosters with continuous mass) the earth connection between s88 feedback module and other components is made via the earth line in the s88 bus cable.

In digital layouts with boosters galvanically separated, the earth connection X2 of the S88-6 module has to be connected to a separate earth line or to mass of the rails. This applies especially to layouts with DCC conform boosters, but as well to layouts controlled by the central station of Märklin** or the Ecos of ESU**.

Connecting the track sections and the earth connection

There are terminal strips soldered to the inputs and to the earth connection of the S88-6 which are used to insert and screw on the connecting wires.

Functional test

First connect the output "OUT" of the S88-6 to the central unit, the memory or the interface for a functional test. Fix a connecting cable to the module's earth connection X2 and connect it one after the other to all 16 inputs. Check if the correct status message is shown for all inputs.

Installing in the layout

After performing a successful functional test install the S88-6 at the desired place on your model railway. Connect the inputs 1 to 16 to the mass contacts and connect the module to the central unit, the memory or the interface or to another feedback module.

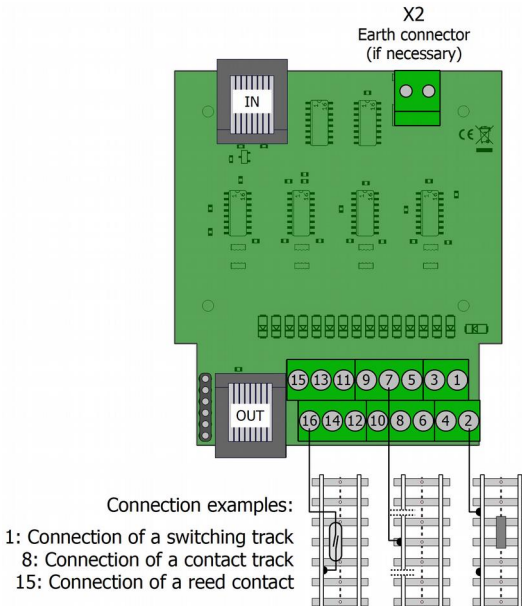

4. Checklist for troubleshooting and error correction

 **Warning:** If you notice a strong heat development, immediately disconnect the connection to the supply voltage. **Fire hazard!**

Possible causes:

- One or more connections are faulty. → Check the connections.
- The module is defective. → Send the feedback module in for inspection.

Faulty display of the states

The central unit, the memory or the interface do not show the proper status.

Possible causes:

- The connection(s) between the feedback module and other feedback modules and/or digital devices are interrupted. → Check the connections. When using a ribbon cable, check as well, if the connecting socket of the ribbon cable is put on in the right direction.
- The connection between the input and the mass contact is interrupted. → Check the connections.

4.1. Technical Hotline

If you have any questions about the use of your s88 feedback module, our technical hotline will help you (telephone number and e-mail address on the last page).

4.2. Repairs

You can send us defective modules for repair (address on the last page). In the event of a warranty or guarantee claim, the repair is free of charge for you. As proof of any warranty or guarantee claim, please enclose the proof of purchase with your return.

If there is no warranty or guarantee claim, we are entitled to charge you the costs of the repair and the costs of the return shipment. We charge a maximum of 50% of the new price for the repair according to our valid price list. We reserve the right to refuse the repair if it is technically impossible or uneconomical.

If you want to clarify whether a repair is possible or economical before sending it in, please contact our Technical Hotline (telephone number and email address on the last page).

Please do not send us repair shipments freight collect. In the event of a warranty or guarantee claim, we will reimburse you for the regular shipping costs.

5. Technical data

Feedback log	s88
Number of mass contacts	16
Connections to the s88-bus	OUT: RJ-45 according to S88-N or 6-pole plug connector IN: RJ-45 according to S88-N

Electrical characteristics

Supply voltage	5 – 15 V d.c. voltage (provided by the s88-bus)
----------------	--

Protection

Protection class	Ready-made module (without housing): IP 00 Meaning: No protection against foreign bodies, contact and water. Ready device (in housing): IP 20 Meaning: Protected against solid foreign bodies with diameter ≥ 12.5 mm and access with a finger. No protection against water.
------------------	--

Environment

	For use in closed rooms
Ambient temperature during operation	0 ~ + 30 °C
Permissible relative humidity during operation	10 ~ 85% (non-condensing)
Ambient temperature during storage	- 10 ~ + 40 °C
Permissible relative humidity during storage	10 ~ 85% (non-condensing)

Other features

Dimensions (approx.)	Circuit board: 72 x 82 mm Ready device including housing: 100 x 90 x 35 mm
Weight (approx.)	Assembled board (ready-made module): 48 g Ready device including housing: 96 g

6. Warranty, EU conformity & WEEE

6.1. Guarantee bond

For this product we issue voluntarily a guarantee of 2 years from the date of purchase by the first customer, but in maximum 3 years after the end of series production. The first customer is the consumer first purchasing the product from us, a dealer or another natural or juristic person reselling or mounting the product on the basis of self-employment. The guarantee exists supplementary to the legal warranty of merchantability due to the consumer by the seller.

The warranty includes the free correction of faults which can be proved to be due to material failure or factory flaw. With kits we guarantee the completeness and quality of the components as well as the function of the parts according to the parameters in not mounted state. We guarantee the adherence to the technical specifications when the kit has been assembled and the ready-built circuit connected according to the manual and when start and mode of operation follow the instructions.

We retain the right to repair, make improvements, to deliver spares or to return the purchase price. Other claims are excluded. Claims for secondary damages or product liability consist only according to legal requirements.

Condition for this guarantee to be valid, is the adherence to the manual. In addition, the guarantee claim is excluded in the following cases:

- if arbitrary changes in the circuit are made,
- if repair attempts have failed with a ready-made module or device,
- if damaged by other persons,
- if damaged by faulty operation or by careless use or abuse.

6.2. EU Declaration of Conformity

 This product fulfils the requirements of the following EU directives and therefore bears the CE marking.

2001/95/EU Product Safety Directive

2015/863/EU on the restriction of the use of certain hazardous substances in electrical and electronic equipment (RoHS)

2014/30/EU on electromagnetic compatibility (EMC Directive). Underlying standards:

DIN-EN 55014-1 and 55014-2: Electromagnetic compatibility - Requirements for household appliances, electric tools and similar electrical appliances. Part 1: Emitted interference, Part 2: Immunity to interference

To maintain electromagnetic compatibility during operation, observe the following measures:
Only connect the supply transformer to a professionally installed and fused earthed socket.

Do not make any changes to the original components and follow the instructions, connection and assembly diagrams in this manual exactly.

Only use original spare parts for repair work.

6.3. Declarations on the WEEE Directive

This product is subject to the requirements of the EU Directive 2012/19/EC on Waste Electrical and Electronic Equipment (WEEE), i.e. the manufacturer, distributor or seller of the product must contribute to the proper disposal and treatment of waste equipment in accordance with EU and national law. This obligation includes

- registration with the registering authorities ("registers") in the country where WEEE is distributed or sold
- the regular reporting of the amount of EEE sold
- the organisation or financing of collection, treatment, recycling and recovery of the products
- for distributors, the establishment of a take-back service where customers can return WEEE free of charge
- for producers, compliance with the Restriction of the Use of Certain Hazardous Substances in Electrical and Electronic Equipment (RoHS) Directive.



The "crossed-out wheeled bin" symbol means that you are legally obliged to recycle the marked equipment at the end of its life. The appliances must not be disposed of with (unsorted) household waste or packaging waste. Dispose of the appliances at special collection and return points, e.g. at recycling centres or at dealers who offer a corresponding take-back service.

Further Information and Tips:

<http://www.tams-online.de>

Warranty and Service:

Tams Elektronik GmbH

Fuhrberger Straße 4
DE-30625 Hannover

fon: +49 (0)511 / 55 60 60

fax: +49 (0)511 / 55 61 61

e-mail: modellbahn@tams-online.de

