

Manual

WIB-33.2

Carriage lighting
with integrated function decoder
Colour of lighting: warm white

Item no. 53-01340

Version 2016
with OSRAM LEDs
Duris E5



Table of contents

1. Getting started.....	3
2. Safety instructions.....	4
3. Safe and correct soldering.....	5
4. Operation overview.....	6
5. Technical specifications.....	9
6. Mounting the carriage lighting.....	10
6.1. Overall view.....	10
6.2. Connection to the power supply.....	11
6.3. Connecting bridging capacitors.....	11
6.4. Connecting a light depending resistor.....	11
6.5. Connecting LEDs to the output AUX2.....	12
6.6. Connecting auxiliary devices to the outputs AUX1 and AUX3	12
6.7. Connecting PCB section 2.....	12
6.8. Setting the LEDs´ brightness.....	13
6.9. Fixing the carriage lighting.....	13
7. Programming the function decoder.....	13
8. Configuration variables and registers.....	14
9. Presets.....	19
10. Check list for troubleshooting.....	20
11. Guarantee bond.....	21
12. EU declaration of conformity.....	21
13. Declarations conforming to the WEEE directive.....	21

© 11/2016 Tams Elektronik GmbH

All rights reserved. No part of this publication may be reproduced or transmitted in any form or by any means, electronic or mechanical, including photocopying, without prior permission in writing from Tams Elektronik GmbH.

Subject to technical modification.

Remark: RailCom® is the registered trademark of the Lenz Elektronik GmbH, Hüttenbergstraße 29, D-35398 Gießen. To increase the text´s readability we have refrained from referring to this point in each instance.

The asterisks **

This manual mentions the following companies:

Gebr. MÄRKLIN** & Cie. GmbH | Postfach 8 60 | D-73008 Göppingen

1. Getting started

How to use this manual

This manual gives step-by-step instructions for safe and correct fitting and connecting of the module, and operation. Before you start, we advise you to read the whole manual, particularly the chapter on safety instructions and the checklist for trouble shooting. You will then know where to take care and how to prevent mistakes which take a lot of effort to correct.

Keep this manual safely so that you can solve problems in the future. If you pass the module on to another person, please pass on the manual with it.

Intended use

The carriage lightings are designed to be operated according to the instructions in this manual in model building and with model railways. Any other use is inappropriate and invalidates any guarantees.

The carriage lightings should not be mounted by children under the age of 14.

Reading, understanding and following the instructions in this manual are mandatory for the user.



Caution:

Integrated circuits (ICs) are inserted on the module. They are sensitive to static electricity. Do not touch components without first discharging yourself. Touching a radiator or other grounded metal part will discharge you.

Checking the package contents

Please make sure that your package contains:

- one or six carriage lightings
- one or six light dependent resistors
- two or twelve red LEDs
- a CD (containing the manual and further information)

Required materials

For connecting the carriage lighting you need:

- an electronic soldering iron (max. 30 Watt) or a regulated soldering iron with a fine tip and a soldering iron stand,
- a tip-cleaning sponge,
- a heat-resistant mat,
- a small side cutter and wire stripper,
- as necessary a pair of tweezers and long nose pliers,
- electronic tin solder (0,5 mm. Diameter),
- wire (diameter: $\geq 0,05 \text{ mm}^2$ for all connections).

If you intend to shorten the module: a small metal saw.

If necessary, for the external power supply of the LEDs:

- an electrolytic capacitor with a voltage sustaining capability of $\geq 16 \text{ V}$ or
- two goldcaps with a voltage sustaining capability of $> 5,5 \text{ V}$.

If necessary, for the external power supply of the decoder's function outputs: an electrolytic capacitor with a voltage sustaining capability of $\geq 25 \text{ V}$ or $\geq 35 \text{ V}$ (when connecting it to analogue a.c. voltage).

If necessary, a rectifier (see section 6, connecting part 2).

2. Safety instructions

Mechanical hazards

Cut wires can have sharp ends and can cause serious injuries. Watch out for sharp edges when you pick up the PCB.

Visibly damaged parts can cause unpredictable danger. Do not use damaged parts: recycle and replace them with new ones.

Electrical hazards

- Touching powered, live components,
 - touching conducting components which are live due to malfunction,
 - short circuits and connecting the circuit to another voltage than specified,
 - impermissibly high humidity and condensation build up
- can cause serious injury due to electrical shock. Take the following precautions to prevent this danger:
- Never perform wiring on a powered module.
 - Mounting should only be done in closed, clean, dry rooms. Beware of humidity.
 - Only use low power for this module as described in this manual and only use certified transformers.
 - Connect transformers and soldering irons only in approved mains sockets installed by an authorised electrician.
 - Observe cable diameter requirements.
 - After condensation build up, allow a minimum of 2 hours for dispersion.
 - Use only original spare parts if you have to repair the kit or the ready-built module.

Fire risk

Touching flammable material with a hot soldering iron can cause fire, which can result in injury or death through burns or suffocation. Connect your soldering iron or soldering station only when actually needed. Always keep the soldering iron away from inflammable materials. Use a suitable soldering iron stand. Never leave a hot soldering iron or station unattended.

Thermal danger

A hot soldering iron or liquid solder accidentally touching your skin can cause skin burns. As a precaution:

- use a heat-resistant mat during soldering,
- always put the hot soldering iron in the soldering iron stand,
- point the soldering iron tip carefully when soldering, and
- remove liquid solder with a thick wet rag or wet sponge from the soldering tip.

Dangerous environments

A working area that is too small or cramped is unsuitable and can cause accidents, fires and injury. Prevent this by working in a clean, dry room with enough freedom of movement.

Other dangers

Children can cause any of the accidents mentioned above because they are inattentive and not responsible enough. Children under the age of 14 should not be allowed to mount the modules.

**Caution:**

Little children can swallow small components with sharp edges, with fatal results! Do not allow components to reach small children.

In schools, training centres, clubs and workshops, mounting and operation must be supervised by qualified personnel.

In industrial institutions, health and safety regulations applying to electronic work must be adhered to.

3. Safe and correct soldering

 **Caution:**

Incorrect soldering can cause dangers through fires and heat. Avoid these dangers by reading and following the directions given in the chapter **Safety instructions**.

- Use a small soldering iron with max. 30 Watt. Keep the soldering tip clean so the heat of the soldering iron is applied to the solder point effectively.
- Only use electronic tin solder with flux.
- When soldering electronic circuits never use soldering-water or soldering grease. They contain acids that can corrode components and copper tracks.
- Solder quickly: holding the iron on the joints longer than necessary can destroy components and can damage copper tracks or soldering eyes.
- Apply the soldering tip to the soldering spot in such a way that the wire and the soldering eye are heated at the same time. Simultaneously add solder (not too much). As soon as the solder becomes liquid take it away. Hold the soldering tip at the spot for a few seconds so that the solder flows into the joint, then remove the soldering iron.
- The joint should be held still for about 5 seconds after soldering.
- To make a good soldering joint you should use a clean and unoxidised soldering tip. Clean the soldering tip with a damp piece of cloth, a damp sponge or a piece of silicon cloth.
- After soldering check (preferably with a magnifying glass) tracks for accidental solder bridges and short circuits. This would cause faulty operation or, in the worst case, permanent damage. You can remove excess solder by putting a clean soldering tip on the spot. The solder will become liquid again and flow from the soldering spot to the soldering tip.

4. Operation overview

Possibilities of use

The carriage lighting WIB-33.2 can be used in digital layouts driven in DCC or Motorola format as well as in analogue model railroad layouts. For the power supply digital boosters or analogue a.c. or d.c. transformers can be used.

Design of the PCB

The carriage lighting WIB-33.2 have inserted 8 warm white LEDs. On the PCB (or after shortening the PCB, on the remaining section 1) are apart from the LEDs:

- RailCom compatible function decoder for DCC and Motorola format,
- three switchable outputs for supplementary loads (e.g. back lighting, additional lighting, electric couplings),
- integrated smoothing capacitor as a flickering protection,
- connecting points for two external bridging capacitors to supply the LEDs and the function outputs of the decoder.

Section 1 with function decoder		Section 2 without function decoder	
length [mm] appr.	number of LEDs	length [mm] appr.	number of LEDs
240	8	0	0
210	7	30	1
176	6	64	2
142	5	98	3
117	4	123	4
75	3	165	5

The length of the PCB as well as number and layout of the LEDs correspond to the carriage lighting WIB-13.2. Thus the (analogue) carriage lighting WIB-13.2 is suitable especially for combining with the lighting of the 30s series in a block train.

Driving in digital Operation

There is a function decoder integrated on the PCB, that can operate with and automatically recognises both DCC or Motorola formats.

The number of addresses is dependant on the format being used.

- Motorola-Format: 255 addresses
- DCC- Format: 127 Basis-addresses or 10.239 extended addresses.

In the DCC format the decoder can be driven in all speed levels (14, 28 or 128).

Programming the decoder is done in DCC format by setting the configuration variables and in Motorola format through the registers.

Switching the functions in digital mode

The LEDs on the PCB, the three function outputs of the decoder and further functions are switched via the function F0 to F15 in DCC format. In Motorola format the function keys F0 to F4 are available. The functions F5 to F9 can be switched via the function keys F1 to F4 and F0 by assigning them to a second address. The functions F10 to F15 are not available in Motorola format.

The assignment of the function keys to

- the LEDs,
- the function outputs of the decoder,
- further functions (switching on and off the orientation light and the dimmer switch)

can be done freely. It is possible to assign several function keys to one LED, one function output or one function.

Operation in analogue mode

The carriage lighting WIB-33.2 can also be used in analogue model railway layouts. When putting the vehicle on the rails the decoder recognizes automatically if it is run in analogue or digital mode and sets the corresponding operation mode. The automatic recognition of the analogue mode can be switched off.

Switching the LEDs and the function outputs on or off is not possible in analogue mode. They can be programmed so that they are either switched on or off in analogue mode. The effects set for the outputs are active in analogue mode as well.

In analogue layouts supplied with d.c. voltage, the function outputs switched with F0 are switched on and off according to the direction of travel. This is not possible in analogue a.c. layouts as the decoder does not recognize the impulse for changing the direction of travel.

Activating the LEDs

The eight LEDs can be switched on and off individually, in groups or corporately. By programming the decoder accordingly you can

- set the LEDs' brightness individually for each LED,
- switch the LEDs according to the direction of travel,
- simulate fluorescent tubes when switching on the LEDs,
- set the duration of the switching on of the fluorescent tube simulation until reaching a constant light and a defective fluorescent tube individually for each LED.

You can switch from standard lighting to orientation light with a function key (e.g. for holded carriages or sleeping cars). The orientation light's brightness is set corporately for all LEDs.

Instead of programming the LEDs' brightness with a digital control unit you can set it with a trim-pot (corporately for all LEDs). The brightness programmed via CVs or register remains active, the settings at the trim-pot only alter the brightness with a factor valid for all LEDs.

Activating the additional function outputs

There are three outputs for external loads on the PCB controlled by the integrated decoder. The output AUX2 is designed for the connection of LEDs for the back lighting. The necessary series resistors are integrated on the PCB.

The two outputs AUX1 and AUX3 are available e.g. for the connection of additional lighting (e.g. in the driver's cabin or in the toilet cabin) or electric couplings. Their maximum current is 300 mA.

It is possible to switch all outputs dependent on the direction of travel and to dim them.

Besides, the two outputs AUX 1 and AUX 3 provide:

- Kick function for special types of electric couplings needing a reduction of the connected voltage after the switching operation in order to protect the coupling.
- Random switch switching on and off the output in irregular intervals (e.g. for the lighting of a toilet cabin).

Connecting a light dependent resistor

When a light dependent resistor is connected, the LEDs and the decoder's function outputs can be switched on and off automatically depending on the surrounding lighting. The sensitivity is set via CVs or registers. You can activate the dim switch with a function key.

The dim switch effects only those outputs switched on. As soon as the outputs have been switched off by the dim switch they cannot be switched on with a function key. In this case the dim switch has to be deactivated first.

With the initial settings the LEDs are switched on as soon as the surrounding lighting under-runs the set limit value. It is possible to invert this functionality, e.g. in order to automatically switch off the lighting in a shadow station.

Flickering protection

An integrated smoothing capacitor supplies the LEDs when short current interruptions occur, which prevents the lighting from flickering when points or smudges on the rails are crossed. In case the integrated smoothing capacitor is not sufficient, you can connect an additional external bridging capacitor with a minimal voltage sustaining capability

of 16 V or two goldcaps with a minimal voltage sustaining capability of 5,5 V.

In order to supply the three function outputs of the decoder you can connect a second additional external bridging capacitor. It is not possible to use goldcaps here, as the minimal voltage sustaining capability is 25 V or 35 V (when connecting the PCB to analogue a.c. voltage).

Feedback with RailCom

RailCom is a log for bi-directional communication in digital model railway layouts controlled in DCC-format. It allows e.g. the feedback of the address and the CV values from the decoder to the digital control unit or to special receivers (so-called detectors). The decoders must be designed to send the RailCom messages.

When so programmed, the integrated function decoder sends (continuously) the (basic, extended or consist) address to the detectors (so-called RailCom broadcast datagramm) and transfer a CV message after a DCC CV read-out command.

Sending RailCom messages is only possible in layouts with a DCC signal on the rails. That is the reason why it is not possible to use the RailCom-function in a pure Motorola environment, but only when at least one other locomotive or function decoder on the layout is controlled in DCC format.

5. Technical specifications

Data format	DCC, Motorola
Address range	MM: 1020 DCC: 2040 Hint: The address range to be used also depends from the control unit.
Speed levels (DCC-Format)	14, 28 or 128
Feedback log	RailCom
Supply voltage	Digital voltage of the central unit or analogue d.c. or a.c. voltage
Minimum supply voltage approx.	7 V (yellow LEDs) 8 V (white LEDs)
Maximum supply voltage	24 Volt
Current consumption at maximum brightness (without connected loads approx.	50 mA
Number of outputs	3
Maximum current of the function outputs: AUX 1 and 3 AUX 2	300 mA each 20 mA
Connection for bridging capacitor / gold cap for the supply of the LEDs	1 electrolytic capacitor $\geq 100 \mu\text{F} / \geq 16 \text{ V}$ or gold cap $\geq 5,5 \text{ V}$
Connection for bridging capacitor for the supply of the integrated decoder's outputs	1 electrolytic capacitor $\geq 100 \mu\text{F} / \geq 25 \text{ V}$ with connection to analogue a.c. voltage: electrolytic capacitor $\geq 100 \mu\text{F} / \geq 35 \text{ V}$
LEDs	8 x OSRAM Duris E5 (warm white) dimensions: 5,6 x 3,0 x 0,6 mm colour temperature: 3.000 K luminous intensity: 15.000... 19.400 mcd angle of reflected beam: 120°
Protected to	IP 00
Ambient temperature in use	0 ... +60 °C
Ambient temperature in storage	-10 ... +80 °C
Comparative humidity allowed	max. 85 %
Dimensions of the PCB approx.	9 x 240 mm
Weight of the PCB approx.	6 g

6. Mounting the carriage lighting

6.1. Overall view

	P1 ... P6	power supply
	E(+) E(-)	external bridging capacitor
	AUX1 AUX3	decoder outputs max. current: 300 mA
	AUX2	decoder output for therconnection of LEDs (back lighting) max. current: 20 mA
	RL1 RL2	return conductor for decoder outputs AUX1 and AUX3
	RL2	return conductor for decoder output AUX2
	LDR1 LDR2	light depending resistor
	L4 ... L8	wwitching input for LED4 ... LED8 (with separate connection of section 2)
	RL3	return conductor for L4 ... L8
	<p>Shortening the carriage lighting</p> <p>You can divide or shorten the print at the marked spots!</p> <div style="border: 1px solid black; padding: 5px;"> <p>! Caution: Pay attention not to damage the connection pads or the parts on the PCB when sawing.</p> </div> <p>After shortening the PCB you get :</p> <p>Section 1 with integrated function decoder, with integrated smoothing capacitor, with connecting points for external bridging capacitors and light dependent resistor (LDR)</p> <p>Section 2 without integrated function decoder, without integrated smoothing capacitor, without connecting points for external bridging capacitors and light dependent resistor (LDR)</p>	

6.2. Connection to the power supply

Solder the connecting wires for the power supply to the connecting points P1, P3 or P5 (from the left rail) and the connecting points P2, P4 or P6 (from the right rail).

You can loop through the power supply from one PCB to the next and thus supply several carriage lighting from one current source.

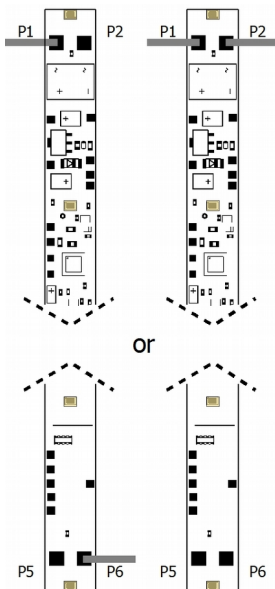

⚠ Caution:
When using power transmitting couplings pay attention not to exceed the maximum current of the couplings!

6.3. Connecting bridging capacitors

In order to bridge currentless sections you can connect external bridging capacitors to the PCB (section 1).

For the supply of

- the LEDs: an electrolytic capacitor with a voltage sustaining capability of $\geq 16\text{ V}$ or two goldcaps with a voltage sustaining capability of $\geq 5,5\text{ V}$. Solder them to the connecting points E1(+) and E1(-).
- Loads connected to the outputs of the integrated function decoder: an electrolytic capacitor with a voltage sustaining capability of $\geq 25\text{ V}$ or, when connecting it to analogue a.c. voltage, $\geq 35\text{ V}$. Solder it to the connecting points E2(+) and E2(-).

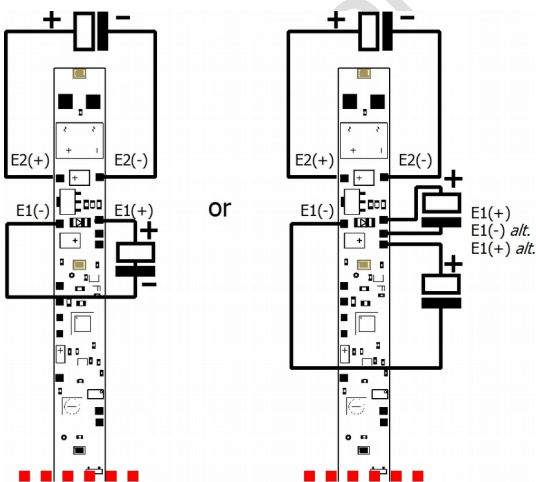

Choose an electrolytic capacitor or a goldcap with a capacity as high as possible. As the housings of electrolytic capacitors and goldcaps are bigger when the capacity is higher, the maximum capacity is limited by the space available to mount the capacitor.

6.4. Connecting a light depending resistor

You can switch on and off the LEDs and the decoder's function outputs automatically depending on the surrounding lighting when mounting a light depending resistor to the connecting points LDR1 and LDR2.

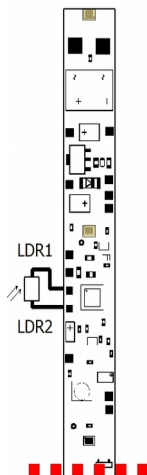

6.5. Connecting LEDs to the output AUX2

The output AUX2 has been designed for the connection of LEDs for the back lighting. The maximum current is 20 mA. The necessary series resistors are integrated on the PCB. Solder the LEDs to the connecting points AUX2 and RL2.

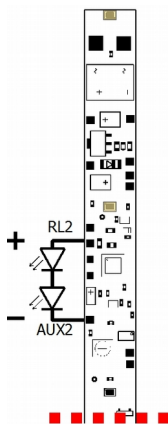

! Caution:

Do not connect electric bulbs to the output AUX2! These have normally a current of more than 20 mA. The output will be damaged when setting-up operation.

6.6. Connecting auxiliary devices to the outputs AUX1 and AUX3

Before connecting additional lighting, couplings or other auxiliary devices to the outputs AUX1 and AUX3, check if their current is below the maximum permissible value of 300 mA. If connecting devices with a higher current to the PCB, the output will be damaged in the setting-up operation.

Disconnect any existing diodes in the leads to the lamps. If the lamp or the accessory is already connected to vehicle ground, you have to connect it to the output only. If not, connect the second side of the accessory to the return conductor of the decoder (point RL1).

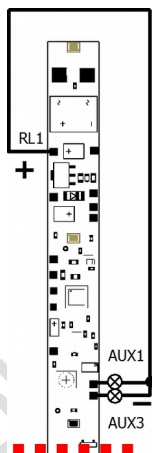

! Caution:

If you connect the accessories to the return conductor for all functions (point RL1), the accessories must be insulated. The accessories should not make contact with metal parts of the vehicle. Possible short circuit! The module will be damaged in operation.

! Caution:

The return conductor for all functions (point RL1) must under no circumstances be connected to vehicle ground. Possible short circuit! The module will be damaged in operation.

6.7. Connecting PCB section 2

You can use section 2 of the PCB you have sawed off as a LED PCB. Either connect it to the output of a locomotive or function decoder (e.g. the integrated function decoder of section 1) and switch the LEDs digitally or connect it directly to an analogue power supply.

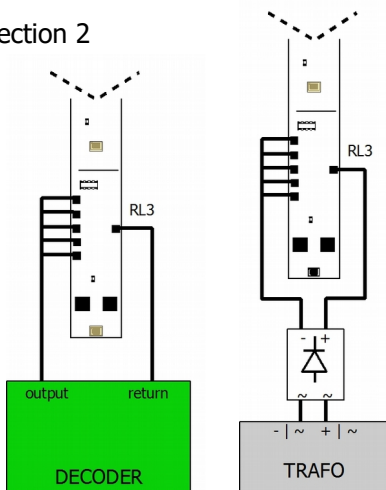

The five connecting points L4 to L8 are assigned to the LEDs 4 to 8 on the PCB. When connecting the connecting points separately to the outputs of a decoder you can activate each of the LEDs separately in digital operation.

Connect the connecting point RL3 to the return conductor of the decoder or to the analogue power supply. When using the PCB in analogue layouts you have to mount a rectifier.

6.8. Setting the LEDs' brightness

Instead of programming with a digital control unit you can set the LEDs' brightness via a trim-pot (see digram in section 6.1). For setting the trim-pot use a small screw-driver.

The brightness programmed via CVs or register remains active, the settings at the trim-pot only alter the brightness with a factor valid for all LEDs.

6.9. Fixing the carriage lighting

After completing the connections, secure the lighting in place (eg. with double sided adhesive tape).

7. Programming the function decoder

You can program the integrated function decoder with a digital control unit.

- In DCC format: via configuration variables (CVs) or main track programming. With DCC control unit allowing only register programming you can set the register 1 and 5 (corresponding CV#1 and CV#29) only.
- In Motorola format: via registers.

Please note: When programming the decoder, there should be mounted no buffer capacitor or goldcap to E1 or E2, otherwise problems can occur (e.g. error messages).

Programming with DCC central units

See the chapter in the manual of your central unit where the byte wise programming of configuration variables (CVs) is explained.

Programming with Motorola central units

Please note: If you use a central unit for both DCC and Motorola format it is recommended to program the decoder in the DCC format. After having finished programming the decoder it is possible to control it in Motorola format as well.

Put the vehicle on a track oval or a track section connected to the central unit's track output (not to the connection for the programming track). Make sure no other vehicle than the one you intend to program is set on the track as the decoder inside this vehicle might be programmed as well.

During the programming operation the LEDs show, which input the decoder expects:

LEDs flash	LEDs stop to flash
Number of the register to be programmed	Value of the register to be programmed

Starting the programming mode	Programming the decoder
<ol style="list-style-type: none"> 1. Switch on the central unit or perform a reset at the central unit (pushing "stop" and "go"). 2. Set the current decoder address (default value: 3) or the address "80". 3. Set all functions to "off". 4. Push button "stop" → switch off the track voltage. 5. Operate the direction switch and hold it in that position. Push the button "go" at once. 6. As soon as the LEDs flash, release the direction switch. 	<ol style="list-style-type: none"> 1. Enter the number of the register as a Motorola-address. <i>If necessary: with a leading "0".</i> 2. Operate the direction switch. → LEDs stop to flash. 3. Enter the value you want to set into the register (as Motorola-address). 4. Operate the direction switch. → LEDs start to flash. <p>Repeat steps 1 – 4 for all registers.</p> <p>Push button "stop".</p>
→ Programming mode	→ End of programming mode

Programming with the Central Station and the Mobile Station

With the Central Station or the Mobile Station of Märklin* you can program the registers, but the value to be set is limited to 80. Select the article no. 29750 from the locomotive database and program the decoder as described for this article in the Central Station's or Mobile Station's manual.

Programming with the CV-Navi

Instead of programming the configuration variables or registers of the decoder using the digital central unit, you can use the free software CV-Navi. You will find the free download under:

www.tams-online.de

8. Configuration variables and registers

The following list shows all configuration variables (for the DCC format) and registers (for the Motorola format), that can be set for the integrated function decoder.

In the list you will find in the column "CV-no." the numbers of the configuration values for programming in DCC format and in the column "Reg.-no." the numbers of the registers for programming in Motorola format. The defaults are those values set in the state of delivery and after a reset.

If you do not want to program all configuration variables or registers individually you can fall back on different presets (see CV#130 and section 9.)

Please note: With variables destined to set several parameters, the input value has to be calculated by adding the numerical values assigned to the desired parameters.

Setting the address

Name of CVs / Registers	CV-no.	Reg. no.	Input value (Default)	Remarks and Tips Settings
Basic address	1	01	1 ... 255 (3)	Range of values in DCC format: 1 ... 127 MM format: 1 ... 255
Tip: If a value higher than 127 is set for the basic address and the use of extended addresses in CV#29 is set to off, the decoder does not react to signals in DCC format!				
Extended address	17	06	192 ... 255 (192)	Only for DCC format. Most central units permit entering extended addresses directly. The CVs # 17, 18 and 29 are set automatically to the proper values.
	18	07	0 ... 255 (255)	
Consistadresse	19	08	1 ... 127 (0)	= 2 nd address In DCC format only!
2nd Motorola address	114	39	1 ... 255 (4)	= Address needed to switch additional functions in Motorola format. The function keys F5 to F8 are reached via the function keys F1 to F4, the function key F9 via the function key F0.

Information / Read only

Name of CVs / Registers	CV-no.	Reg. no.	Input value (Default)	Remarks and Tips Settings
Version	7	---	---	Read only in DCC format!
Manufacturer	8	---	(62)	Read only in DCC format!

Auxiliary functions

Name of CVs / Registers	CV-no.	Reg. no.	Input value (Default)	Remarks and Tips Settings
Reset	8	03	0 ... 255	Any input value restores the settings in state of delivery.

Basic settings

Name of CVs / Registers	CV-no.	Reg. no.	Input value (Default)	Remarks and Tips Settings
Configuration data 1	29	10	0 ... 64 (14)	Direction "Standard" 0
				Reverse direction 1
				14 speed levels 0
				28 or 128 speed levels 2
				Analogue recognition off 0
				Analogue recognition on 4
				RailCom off 0
				RailCom on 8
Not for MM mode:				Extended addresses 32
Factory settings: Direction of travel = "Standard". 28 or 128 speed levels. Automatic analogue recognition = "on". RailCom "on". Basic addresses.				
Example: CV#29 = 0. → Direction = "Standard". 14 speed levels. Automatic analogue recognition = "off". RailCom = "off". Basic addresses.				
Example: CV#29 = 46. → Direction = "Standard". 28 or 128 speed levels in DCC-mode. RailCom = "on". Automatic analogue recognition = "on". Extended Addresses.				
Tip: If the use of extended addresses is activated in CV#29, the decoder does not react to signals in Motorola format!				

Settings for analogue mode

Name of CVs / Registers	CV-no.	Reg. no.	Input value (Default)	Remarks and Tips Settings
Functions active in analogue mode (only for F1 to F8, not for F9 to F12)	13	05	0 ... 255 (15)	F1 on 1
				F2 on 2
				F3 on 4
				F4 on 8
				F5 on 16
				F6 on 32
				F7 on 64
				F8 on 128
Factory settings: F1, F2, F3 and F4 activated in analogue mode (CV#13 = 1+2+4+8=15)				

RailCom settings

Name of CVs / Registers	CV-no.	Reg. no.	Input value (Default)	Remarks and Tips Settings
RailCom-settings (not for operation in Motorola format)	28	--	0, 1, 2, 3 (3)	Broadcast on 0
				Broadcast off 1
				Messages in channel 2 off 0
				Messages in channel 2 on 2
Remark: When using the carriage lighting in a block train with other RailCom decoders it is recommended to switch off the RailCom broadcast. Otherwise disturbances in transmitting the address may occur.				

Basic settings for the LEDs and the outputs

Name of CVs / Registers	CV-no.	Reg. no.	Input value (Default)	Remarks and Tips Settings	
Configuration data 2	115	40	1 ... 255 (4)	Fluorescent tube simulation off 0	
				Fluorescent tube simulation on 1	
				Random light for AUX1 off 0	
				Random light for AUX1 on 2	
				Random light for AUX3 off 0	
				Random light for AUX3 on 4	
				LDR performance "standard" 0	
				LDR performance inverted 8	
Factory settings: Fluorescent tube simulation = "off". AUX3 = random light. Dim switch (via LDR) switches the LEDs and the devices connected to the outputs on when the limit value of the surrounding lighting is under -run. Outputs programmed as random lights cannot be switched via function keys.			function key for LDR	settings in CV#112 define F1-F4 and F0 0	
				settings in CV#112 define F5-F12 16	
				function key for orientation light	settings in CV#118 define F1-F4 and F0 0
					settings in CV#118 define F5-F12 32
				function key for AUX1	settings in CV#121 define F0-F7 0
					settings in CV#121 define F8-F15 64
				function key for AUX3	settings in CV#123 define F0-F7 0
					settings in CV#123 define F8-F15 128

Function keys for switching the 8 LEDs

Name of CVs / Registers	CV-no.	Reg. no.	Input value (Default)	Remarks and Tips Settings
F0 forward on	33	11	0 ... 255 (0)	LED 1 1
F0 backward on	34	12	0 ... 255 (0)	LED 2 2
F1	35	13	0 ... 255 (170)	LED 3 4
F2	36	14	0 ... 255 (85)	LED 4 8
...	0 ... 255 (0)	LED 5 16
F12	46	24	0 ... 255 (0)	LED 6 32
				LED 7 64
				LED 8 128
Factory settings: F1 switches the LEDs 2, 4, 6 and 8 (CV#35 = 2 + 8+ 32 + 128), F2 the LEDs 1, 3, 5 und 7 (CV#36 = 1 + 4+ 16 + 64). The other functions keys do not have any effects on the LEDs.				

Function keys for switching AUX1 and AUX3

Name of CVs / Registers	CV-no.	Reg. no.	Input value (Default)	Value in CV#115		
				0	64 / 128	
AUX1	121	43	1 ... 255 (1)	F0	F8	1
AUX3	123	44	1 ... 255 (64)	F1	F9	2
It is possible to activate the function with several function keys. Remark: If you want to assign the function keys F8 to F15 to this function you have to set the value "64" in CV#115 for AUX1 or/and the value "128" in in CV#115 for AUX3 first. Factory settings: AUX1 is activated with F0, AUX3 with F6 (if in CV#115 the random light for AUX3 is switched off).				F2	F10	4
				F3	F11	8
				F4	F12	16
				F5	F13	32
				F6	F14	64
				F7	F15	128

Function keys for switching AUX2

Name of CVs / Registers	CV-no.	Reg. no.	Input value (Default)	Remarks and Tips Settings
AUX2	122	45	1 ... 255 (1)	F0 1
It is possible to activate the function with several function keys. Factory settings: AUX2 is activated with F0.				F1 2
				F2 4
				F3 8
				F4 16
				F5 32
				F6 64
				F7 128

Dependant on the direction of motion of the LEDs and the outputs

Name of CVs / Registers	CV-no.	Reg. no.	Input value (Default)	Remarks and Tips Settings	
LED1 LED2	53	25	0, 1, 2, 16, 17, 18, 32, 33, 34 (0)	LED 1, 3, 5 or 7 off at backward motion	1
LED3 LED4	54	26	0, 1, 2, 16, 17, 18, 32, 33, 34 (0)	LED 1, 3, 5 or 7 off at forward motion	2
LED5 LED6	55	27	0, 1, 2, 16, 17, 18, 32, 33, 34 (0)	LED 2, 4, 6 or 8 off at backward motion	16
LED7 LED8	56	28	0, 1, 2, 16, 17, 18, 32, 33, 34 (0)	LED 2, 4, 6 or 8 off at forward motion	32
AUX1 AUX2	57	29	0, 1, 2, 16, 17, 18, 32, 33, 34 (18)	AUX1 or AUX3 off at backward motion	1
AUX3	58	30	0, 1, 2 (0)	AUX1 or AUX3 off at forward motion	2
				AUX2 off at backward motion	16
				AUX2 off at forward motion	32

Factory settings: AUX1 switched off at forward motion, AUX2 switched off at backward motion (CV#57 = 2 + 16 = 18)

Dimming of the LEDs and the outputs

Name of CVs / Registers	CV-no.	Reg. no.	Input value (Default)	Remarks and Tips Settings
LED1 LED2	59	31	0 ... 255 (255)	= Reducing the voltage applied to the output A. 1= minimum voltage 255 = maximum voltage
LED3 LED4	60	32	0 ... 255 (255)	
LED5 LED6	61	33	0 ... 255 (255)	
LED7 LED8	62	34	0 ... 255 (255)	
AUX2 AUX1	63	35	0 ... 255 (255)	
AUX3	64	36	0 ... 255 (255)	

You can choose a value between 0 and 15 for each output. Enter the value directly for the odd LEDs and outputs, for the even LEDs and outputs multiply the value by 16.

Example: For LED1 value "14" and for LED2 value "2"

→ Input value in CV#59: $14 + 2 \times 16 = 46$.

With outputs for which a fluorescent tube simulation or a random light have been programmed, the settings in CV #59 to 64 have no effect.

Settings for the dim switch

Name of CVs / Registers	CV-no.	Reg. no.	Input value (Default)	Value in CV#115		
				0	16	
Function keys for activating the dim switch (via LDR)	112	37	1 ... 255 (8)	F1	F5	1
				F2	F6	2
				F3	F7	4
				F4	F8	8
				F0	F9	16
					F10	32
					F11	64
	F12	128				

It is possible to activate the function with several function keys. Remark: If you want to assign the function keys F5 to F12, you have to set the value "16" CV#115 first.

Factory settings: The dim switch can be activated with F4.

Name of CVs / Registers	CV-no.	Reg. no.	Input value (Default)	Remarks and Tips Settings
Sensivity of the LDR (light depending resistor)	113	38	1 ... 255 (176)	= Limit value of the surrounding lighting, when the LEDs and the outputs are switched on or off. A higher value causes the switching operation to be activated at a greater light intensity.

Remark: In default settings the LEDs and the function outputs are switched on when the surrounding lighting under-runs the limit value. When programmed accordingly (in CV#115) the performance can be inverted (e.g. to switch the lighting off automatically in a shadow station).

Settings for the orientation light

Name of CVs / Registers	CV-no.	Reg. no.	Input value (Default)	Value in CV#115		
				0	32	
Function keys for activating the orientation light	118	41	1 ... 255	F1	F5	1
				F2	F6	2
				F3	F7	4
				F4	F8	8
				F0	F9	16
					F10	32
					F11	64
	F12	128				

It is possible to activate the function with several function keys.

Remark: If you want to assign the function keys F5 to F12 to this function you have to set the value "32" in CV#115 first.

Factory settings: The orientation light is activated with F3.

Name of CVs / Registers	CV-no.	Reg. no.	Input value (Default)	Remarks and Tips Settings
Brightness of the orientation light	119	42	1 ... 255 (16)	The lower the input value the brighter is the orientation light.

Settings for the fluorescent tubes

Name of CVs / Registers	CV-no.	Reg. no.	Input value (Default)	Remarks and Tips Settings	
Simulation of a defective fluorescent tube	125	47	0 ... 255 (0)	LED1	1
				LED2	2
				LED3	4
				LED4	8
				LED5	16
				LED6	32
				LED7	64
				LED8	128

Factory settings: The simulation of a defective fluorescent tube is defined for none of the eight LEDs.

Remark: The setting in CV#125 only takes effect when in CV#115 the fluorescent tube simulation has been activated (factory settings fluorescent tube simulation deactivated).

Duration of switching on the fluorescent tubes

LED1 LED2	126	48	0 ... 255 (52)	no flickering	0
LED3 LED4	127	49	0 ... 255 (35)	short flickering	1
LED5 LED6	128	50	0 ... 255 (83)	...	
LED7 LED8	129	51	0 ... 255 (71)	long flickering	15

You can choose a value between 0 and 15 for each output. Enter the value directly for the even LEDs, for the odd LEDs multiply the value by 16.

Example: For LED1 value "2" and for LED2 value "14" → Input value: 46 (=2x16 + 14)

Remark: The settings in CV#125 to 129 only take effect when in CV#115 the fluorescent tube simulation has been activated (in factory settings: fluorescent tube simulation deactivated).

Setting the kicking time for AUX1 and AUX3

Name of CVs / Registers	CV-no.	Reg. no.	Input value (Default)	Remarks and Tips Settings
Kicking time AUX1 AUX3	124	46	0 ... 255 (0)	= length of time the full voltage is applied, before being reduced to the value set in CV#63 or 64. The max. time of 10 seconds corresponds to the value "15".

You can choose a value between 0 and 15 for each output. Enter the value directly for AUX1 and for AUX3 multiply the value by 16.

Example: For AUX1 value "7" and for AUX3 value "3" → Input value: 55 (=7 + 3x16)

Choosing presets

Name of CVs / Registers	CV-no.	Reg. no.	Input value (Default)	Remarks and Tips Settings	
Choosing presets	130	52	--	Preset 0	0
				Preset 1	1
				Preset 2	2
				Preset 3	3

Remark: A set value in this variable can be taken over into operation when you proceed as follows:

1. Performing a reset (i.e. entering an optional value in CV#8).
2. Supplying the vehicle shortly with power (i.e. setting the vehicle shortly onto the powered layout).
3. Entering in CV#130 the desired value, afterwards altering the address and making further modification, if necessary.

9. Presets

	Factory settings (default values)	Preset 0
Applications / Examples	Control car	Switching all functions individually
Switching the LEDs	F1: each 2nd LED F2: remaining LEDs	all LEDs individually with F1 to F8
Dim switch	to be switched with F4	to be switched with F10
Fluorescent tube simulation	off	off
Random light	for AUX3	for AUX3
Orientation light	to be switched with F3	to be switched with F9
AUX1	F0, on at backwards motion	F0, on at backwards motion
AUX2	F0, on at forwards motion	F0, on at forwards motion
AUX3	Random light, not to be switched	Random light, not to be switched

	Preset 1	Preset 2
Applications / Examples	Control units with few function keys	Control units with few function keys
Switching the LEDs	F1: 1 st half of LEDs F2: 2 nd half of LEDs	F1: all LEDs
Dim switch	to be switched with F4	to be switched with F3
Fluorescent tube simulation	off	off
Random light	for AUX3	---
Orientation light	to be switched with F3	to be switched with F2
AUX1	F0, on at backwards motion	F0, on at backwards motion
AUX2	F0, on at forwards motion	F0, on at forwards motion
AUX3	Random light, not to be switched	to be switched with F4

	Preset 3
Applications / Examples	Connection of couplings to AUX1/3
Switching the LEDs	F1: 1 st half of LEDs F2: 2 nd half of LEDs
Dim switch	to be switched with F6
Fluorescent tube simulation	on
Random light	---
Orientation light	to be switched with F5
AUX1	to be switched with F3, Kick function
AUX2	F0, on at forwards motion
AUX3	to be switched with F4, Kick funktion

10. Check list for troubleshooting

- Parts are getting too hot and/or start to smoke.



Disconnect the system from the mains immediately!

Possible cause: one or more connections are soldered incorrectly. → Check the connections.

Possible cause: Short circuit. The module is connected to locomotive or carriage ground. → Check the connections. A short circuit can result in irreparable damage.

- The lighting goes on and off when the speed levels are turned up or the lighting cannot be switched on or off.

Possible cause: The speed mode of the decoder and the digital control unit do not correspond. Example: The central is set to the mode 28 speed levels, but the decoder to the mode 14 speed levels. → Change the speed mode at the central and / or at the decoder.

- The decoder does not react in analogue mode.

Possible cause: The analogue mode is switched off. → Alter the value for CV #29.

- After programming the decoder the functions do not match your ideas.

Possible cause: The set values for the CV are inconsistent. → Perform a decoder reset and first test the decoder with the default values. Program the decoder anew.

- The LEDs do not light and / or the accessories connected to the outputs do not have any function.

Possible cause: The connection to the power supply has been interrupted. → Check the connection of the module.

Possible cause: The dim switch is activated and the limit value is set the wrong way.

→ Check the settings in CV#112, CV#113 and CV#115.

- You cannot switch an output.

Possible cause: The dim switch is activated and has switched off the LEDs and the outputs automatically. → Switch off the dim switch.

Possible cause: In CV#115 there are other address ranges defined to switch the outputs than presumed. → Check the settings in CV#115.

- The lighting and / or other accessories do not correspond to the direction of travel.

Possible cause: The direction of travel is falsely defined in CV#29.

Possible cause: The settings in CV#33, #34 and / or ##53 - 58 are false. → Check the settings.

Hotline

If problems with your module occur, our hotline is pleased to help you (mail address on the last page).

Repairs

You can send in a defective module for repair (address on the last page). In case of guarantee the repair is free of charge for you. With damages not covered by guarantee, the maximum fee for the repair is 50 % of the sales price according to our valid price list. We reserve the right to reject the repairing of a module when the repair is impossible for technical or economic reasons.

Please do not send in modules for repair charged to us. In case of warranty we will reimburse the forwarding expenses up to the flat rate we charge according to our valid price list for the delivery of the product. With repairs not covered by guarantee you have to bear the expenses for sending back and forth.

11. Guarantee bond

For this product we issue voluntarily a guarantee of 2 years from the date of purchase by the first customer, but in maximum 3 years after the end of series production. The first customer is the consumer first purchasing the product from us, a dealer or another natural or juristic person reselling or mounting the product on the basis of self-employment. The guarantee exists supplementary to the legal warranty of merchantability due to the consumer by the seller.

The warranty includes the free correction of faults which can be proved to be due to material failure or factory flaw. With kits we guarantee the completeness and quality of the components as well as the function of the parts according to the parameters in not mounted state. We guarantee the adherence to the technical specifications when the kit has been assembled and the ready-built circuit connected according to the manual and when start and mode of operation follow the instructions.

We retain the right to repair, make improvements, to deliver spares or to return the purchase price. Other claims are excluded. Claims for secondary damages or product liability consist only according to legal requirements.

Condition for this guarantee to be valid, is the adherence to the manual. In addition, the guarantee claim is excluded in the following cases:

- if arbitrary changes in the circuit are made,
- if repair attempts have failed with a ready-built module or device,
- if damaged by other persons,
- if damaged by faulty operation or by careless use or abuse.

12. EU declaration of conformity

 This product conforms with the EC-directives mentioned below and is therefore CE certified.

2004/108/EG on electromagnetic. Underlying standards: EN 55014-1 and EN 61000-6-3. To guarantee the electromagnetic tolerance in operation you must take the following precautions:

- Connect the transformer only to an approved mains socket installed by an authorised electrician.
- Make no changes to the original parts and accurately follow the instructions, connection diagrams and PCB layout included with this manual.
- Use only original spare parts for repairs.

2011/65/EG on the restriction of the use of certain hazardous substances in electrical and electronic equipment (ROHS). Underlying standard: EN 50581.

13. Declarations conforming to the WEEE directive



This product conforms with the EC-directive 2012/19/EG on waste electrical and electronic equipment (WEEE).

Don't dispose of this product in the house refuse, bring it to the next recycling bay.

tams elektronik

tams elektronik

Aktuelle Informationen und Tipps:

Information and tips:

Informations et conseils:

Actuele informatie en tips:

<http://www.tams-online.de>

Garantie und Service:

Warranty and service:

Garantie et service:

Garantie en service:

Tams Elektronik GmbH

Fuhrberger Straße 4

DE-30625 Hannover

fon: +49 (0)511 / 55 60 60

fax: +49 (0)511 / 55 61 61

e-mail: modellbahn@tams-online.de

